

# F1-3 Single Zone Conventional Fire Alarm Panel



## Overview

The Pertronic F1-3 is a low cost, single zone electronic fire alarm control panel for applications where brigade connection is not a requirement.

The F1-3 complies with the NZ Fire Alarm Standard NZS 4512:2010 for single zone fire alarm systems.

The F1-3 supports Pertronic indicating manual call points (MCP), Pertronic indicating heat detectors and System Sensor smoke detectors.

One optional Pertronic 20 Watt evacuation amplifier may be mounted inside the F1-3 fire panel.

## Features

- > Front panel:
  - > Indicators: Fire, Normal, Defect
  - > Key-switches: Trial Evacuation, Silence Alarms
- > Supervised Bell circuit
- > Optional 20 Watt evacuation amplifier with supervised 100 Vrms line output and voice evacuation message. Recommended speakers:
  - Pertronic PSSB401 Speakers
  - Pertronic PSS1 100 Vrms Speakers
  - Pertronic PSS3 100 Vrms Speakers
- > Fire & Defect changeover relays
- > On-board system defect LED indicates source of fault
- > Silence Alarms (BCO) key-switch provides reset and isolate functions (see Technical Manual for details)
- > Automatic Alarm Verification Facility (AVF) protects against transient unwanted alarm activation. The panel rechecks smoke detector alarm signals and responds to confirmed smoke alarms within one second
- > Door Interlock
- > Earth leakage supervision
- > Automatic daily battery and detection circuit test
- > Automatic Battery Absent detection

## Detection Zone Circuits

- > One circuit terminated with 10 kΩ EOL resistors
- > Accepts a mix of System Sensor detectors, Pertronic indicating heat detectors and indicating MCPs
- > The zone circuit may have:
  - Up to 30 System Sensor 2151BPI point smoke detectors
  - A total of 50 Pertronic indicating heat detectors or indicating MCPs
  - (Please refer to the F1 Fire Panel Technical Manual for information about other detector models)
- > Automatic circuit test on start-up and every 24 hours

## Specification

Electrical	
Power Supply	230 Vac 50 Hz, 4 W, 13.7 Vdc 275 mA
Quiescent Current	32 mA @ 12 Vdc
Defect Current	14 mA @ 12 Vdc
Alarm Current	140 mA @ 12 Vdc plus sounder load
Bell Output	12 Vdc 5 A
Battery (Internal)	
Capacity	12 Vdc 7 Ah
Type	Sealed lead acid (gel cell)
Integral Float Charger	13.7 Vdc 250 mA
Environmental	
Operating Temperature	0 to +40° C
Humidity	10 to 95% RH (non-condensing)
Mechanical	
Overall Dimensions	350 x 245 x 87 (H x W x D mm)
Weight	2.2 kg excluding battery
Cabinet Material	1.2 mm mild steel powder coated
Colour	Beige (other colours optional)



The Pertronic F1-3

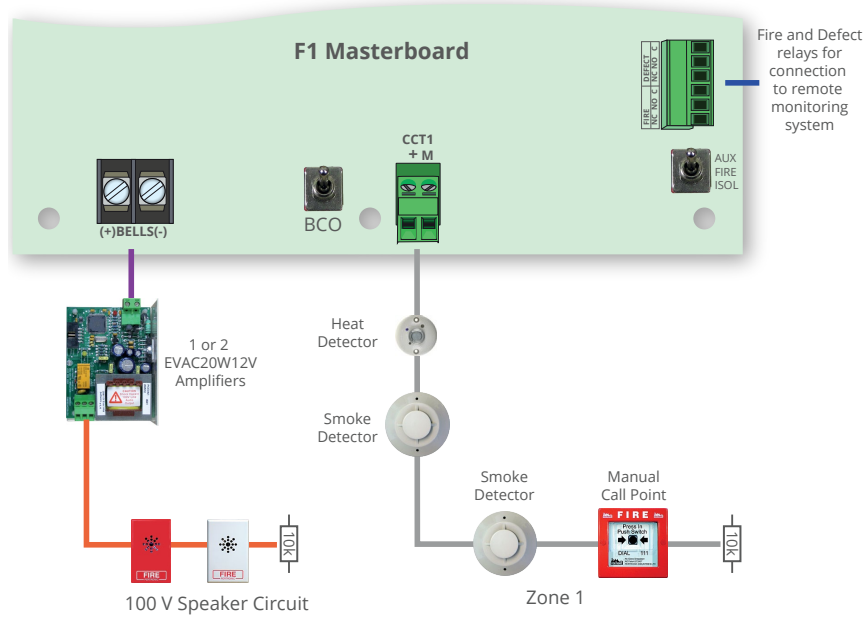

F1-3 System Diagram

## Ordering Information

Product Code	Description	NZFPA Listing
F1-3	F1, 1 cct Panel, 12 Volt, NZS 4512:2010	PI/122
F1-3EA	F1, 1 cct Panel with 20W Evacuation Amplifier, 12 Volt, NZS 4512:2010	PI/122

### Important Note:

- > Non-indicating heat detectors and MCPs will NOT produce a Fire Alarm signal when triggered and MUST NOT be used with the NZS 4512:2010 standard F1-3 panel. A hard short-circuit or open-circuit on a Pertronic NZS 4512:2010 conventional detection circuit will produce a defect signal.

The information in this document must not be treated as partial or complete instructions for the design, construction, installation, commissioning, or maintenance of fire detection, fire alarm, or building evacuation systems. Fire and evacuation systems must be designed and installed by properly qualified persons, in accordance with all regulatory requirements.

Unless explicitly stated otherwise, this document provides typical specifications and nominal dimensions. Actual product performance and dimensions may vary. All information in this document is subject to change. Please consult Pertronic Industries or visit our web site for up to date information.

PERTRONIC® is a registered trademark of Pertronic Industries Limited.

