



F220 Net2 Network

Up to 160 F220 fire panels per network

Dual fibre-optic and/or copper cabling

Native Modbus/TCP interface

ASCII text (printer/pager) interface

Single point programming

– Less than 3-second response time

– Full range of control units and remote displays

– Direct interface with Pertronic FireMap®

– Customisable display and control options

– Fault-tolerant bi-directional ring architecture

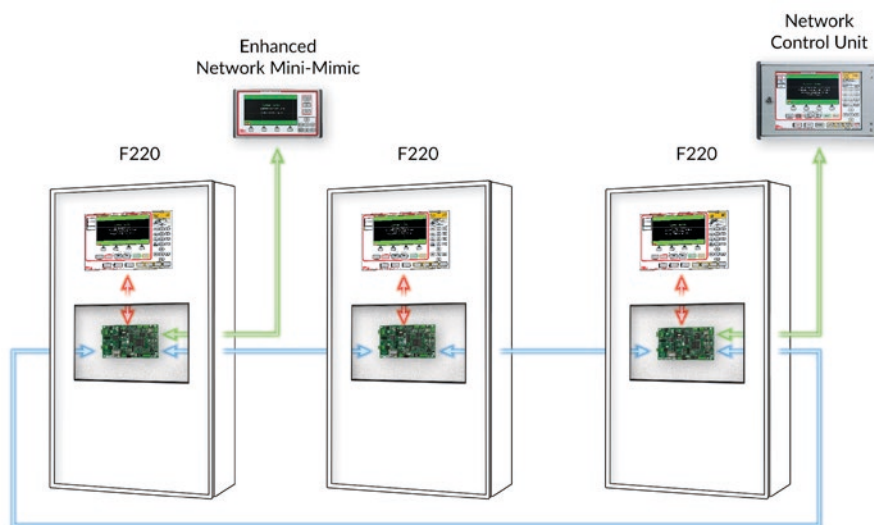

Pertronic F220 Net2 Network System

Product Overview

The Pertronic F220 Net2 Network connects multiple fire panels, Net2 Network Control Units (Net2 NCU) and Net2 remote displays into a single fault-tolerant system.

On a Pertronic F220 Net2 Network:

- » Any or all connected fire panels can be controlled and monitored from any Net2 Network Control Unit
- » Information from any connected fire panel(s) can be viewed on any Net2 NCU or Net2 remote display
- » Events anywhere on the network can trigger or influence events at any connected fire panel

An F220 Net2 Network may include up to 160 Net2 Network Cards (“nodes”). Each network card may connect with up to eight Net2 NCUs or Net2 remote displays (more details on page 3).

A Pertronic Net2 Network Card may be configured to interface one of the following to the network:

- » One F220 fire panel and/or multiple Net2 NCU or Net2 remote displays
- » Modbus master device
- » Pertronic FireMap® work-station
- » ASCII text-based system including printer or pager

A network may include multiple Modbus, FireMap, and/or text nodes.

Adaptive messaging in the F220 Net2 Network prioritises alarms and important control signals to ensure rapid transmission even under extreme network load situations.

Contents

F220 Net2 Network Major Features	2	Net2 Fibre-Optic Converters	6
Network Control Units and Remote Displays	3	Net2 Network Layout and Operation	7
F220 Fire Panel Keyboard & Display Options	3	Single-Point Network Programming	7
Purpose-Built Indicating Boards	3	Ordering Information	7
Net2 Network Card	4	F220 Net2 Network Specification	8
Modbus, FireMap, and ASCII Text Interfaces	5		

F220 Net2 Network Major Features

- » Typical response to new alarm signal: 3 seconds or less
- » Up to 160 nodes per F220 Net2 Network system
- » Plug-in fibre-optic modules allow the standard network interface to support a mix of twisted-pair copper (RS-485) and/or fibre-optic network segments
- » Up to 100,000 panel-to-panel object mappings per F220 Net2 Network System
- » 5,000 object mappings to any individual fire panel
- » 640 directly addressable network inputs per F220 fire panel (multiple objects may be mapped to each input)
- » 359 additional inputs per F220 fire panel, addressable via cause-effect logic
- » Supports zone numbers from 0 to 64,999
- » Plain text descriptors for network inputs, NMOs, NCUs, and remote displays (mini-mimics)
- » Bi-directional Modbus interface provides:
 - » 3,000 Boolean Nodal Mapping Objects (NMOs)
 - » Ability to map up to 8 timers from any fire panels on the network to Modbus registers. (Multiple timers may be mapped to a single register. The total number of mapped timers must not exceed 8.)
- » A single cable fault anywhere in the Net2 Ring Circuit will not interrupt network operation
- » The network is programmable using Pertronic FireUtils® via a single password-protected Ethernet connection
- » Config. programme upload times for typical networks:
 - » 34 nodes: Less than one minute
 - » 160 nodes: Less than five minutes
- » Automatic fault supervision system detects a range of faults including earth faults on copper segments, circuit breaks, and fire panel or node configuration changes
- » Automatic system-wide clock synchronisation
- » Automatic clock adjustment for daylight saving
- » System time and date adjustable from any fire panel
- » Loop devices can be tested from any Net2 NCU
- » Users can reset or disable individual loop devices, alarm routing, timers, logic blocks, and network inputs from any Net2 NCU
- » Recent Network Event log, and fire panel data logs (including history), accessible from Net2 NCUs, fire panels, and full function panel mimics
- » Fire panel data logs downloadable to FireUtils® from any node
- » NET2CARD Linux OS diagnostic logs are available for analysis by Pertronic technical support engineers
- » Significantly exceeds the requirements of AS 1670.1: 2018 and NZS 4512:2021
- » A 160-node Pertronic F220 Net2 Network System has been independently tested to AS 7240.13: 2006 by an IANZ-accredited laboratory
- » Activfire listed (afp-3054) to AS 7240.13:2006

Network Control Units and Remote Displays

A full range of control units and remote displays is available for the Pertronic F220 Net2 Network system. Each F220 Net2 system must have at least one Net2 Network Control Unit (Net2 NCU).

The Net2 NCU may be mapped to display information from any or all F220 fire panels on the network. In addition, each Net2 NCU may be mapped to control any or all of the F220 fire panels from which it displays information. Each Net2 NCU has its own independent scope.

Two types of remote display unit are available for the F220 Net2 Network: The Net2 Alarm Mini-Mimic, and the Net2 Enhanced Mini-Mimic.

Each Pertronic Net2 mini-mimic may be configured to display information from any or all zones on the network. There are no constraints on the scope of individual mini mimics. A mini-mimic can be mapped to individual zones, fire panels, or the entire network. Mini-mimics also provide limited control of fire panels to which they are mapped.

Pertronic Net2 control units and remote displays (mini-mimics) are based on F220 fire panel mimics. When fitted with network firmware, F220 mimics become Net2 control units or Net2 mini-mimics. Please refer to the “F220 & Net2 LCD Mimics” datasheet for full specifications of Net2 Network Control Units and remote displays.

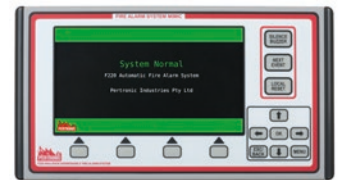

Network Control Unit and Remote Displays (from top):
Net2 Network Control Unit
Net2 Alarm Mini-Mimic
Net2 Enhanced Mini-Mimic

F220 Fire Panel Keyboard & Display Options

The Pertronic F220® fire panel’s keyboard & display may be configured for local or network operation.

- » When configured for local operation, the keyboard & display provides direct control and monitoring of the F220 fire panel only.
- » When configured for network operation, the keyboard & display is functionally identical to a Net2 Network Control Unit.

Any fire panel in an F220 Net2 Network may have either a local or network keyboard & display. However, please note that the network must include at least one Net2 Network Control Unit. This may be a fire panel keyboard & display configured for network control, or a stand-alone Net2 NCU.

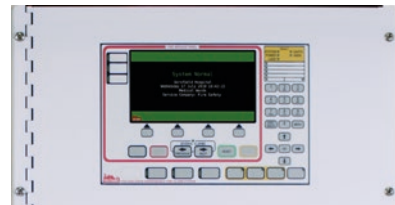

The F220 keyboard & display unit may be configured for local or network operation. When configured for network operation, it is functionally identical to the Net2 NCU.

Purpose-Built Indicating Boards

A Pertronic purpose-built indicating board is an important part of many F220 Net2 systems.

A purpose-built indicating board simplifies the monitoring of automatic equipment such as ventilation fans, dampers, and water deluge systems. A well designed board enables facility staff and fire-fighters to quickly assess the system’s status. If manual intervention is required, the board helps incident managers implement the right decision at the right time.

Successful development of a purpose-built indicating board requires close collaboration between multiple project participants. Please contact us at the beginning of the project to discuss purpose-built CIB requirements



Typical purpose-built indicating boards:
Left Fire fan indicator panel
Right Network zone index

Net2 Network Card

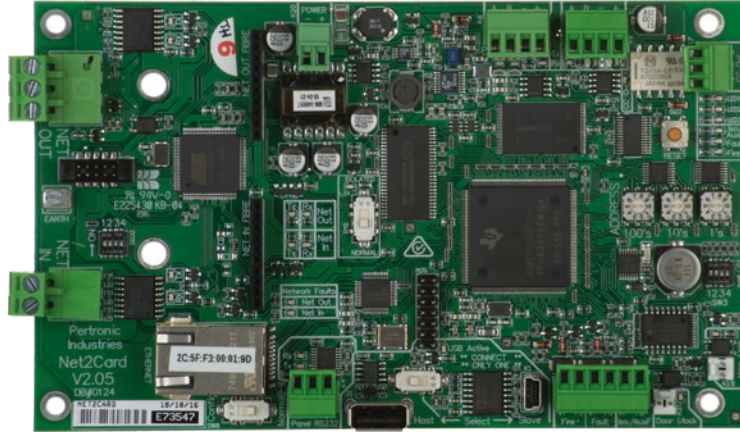

Pertronic Net2 Network Card

The Pertronic Net2 Network Card (NET2CARD) is the central building block for the Pertronic F220 Net2 Network System. This card may be configured to interface one of the following devices to an F220 Net2 Network:

- » One Pertronic F220® fire panel and/or multiple Net2 Network Control Units or Net2 remote displays
- » Pertronic FireMap® workstation
- » Modbus master device
- » ASCII text-based system including nurse-call, printer, or pager

Connections

The Net2 Network Card connects with the Net2 Ring Circuit via two bi-directional ports: Net In and Net Out. Data arriving at either port is regenerated and transmitted from the other port.

The standard ports are electrically-isolated half-duplex RS-485 connections with built-in terminating resistors. Optional plug-in modules allow the Net In and / or Net Out ports to be re-configured as dual fibre full duplex single-mode or multi-mode fibre-optic ports. The network

card is the only device physically connected to the Net2 Ring Circuit.

Net2 peripherals including control units and remote displays connect to the network card via the Network Peripheral Bus. This is electrically similar to the F220 External High-Speed RS-485 Bus and is fully described in the “F220 & Net2 LCD Mimics” datasheet.

The Network Peripheral Bus data circuit can communicate with up to eight Net2 NCUs or Net2 Mini-Mimics. The Network Peripheral Bus power circuit is capable of powering one or two Net2 NCUs or Net2 Mini-Mimics, depending on brightness settings. If additional remote displays or NCUs are required, the bus power circuit should be fed from the panel power supply. On a long bus with several remote displays or NCUs, it may be necessary to install external power supplies to overcome voltage drop.

The Net2 Network Card’s Network Peripheral Bus port has an internal terminating resistor, as required for RS-485 data circuits. However, a terminating resistor must be fitted at the far end of the Network Peripheral Bus, as explained in the “F220 & Net2 LCD Mimics” datasheet.

Net2 Network Card Features

- » Two half-duplex RS-485 network ports (Net In, Net Out) with built-in terminating resistors
- » Isolates any faulty ring segment
- » Three rotary switches for configuring the network node address
- » On-board clock with super-capacitor backup power maintains system time for at least 24 hours without system power
- » Communicates with an F220 fire panel via the F220 Internal High-Speed RS-485 Bus
- » Automatically creates a complete configuration backup of all network card and networked panels whenever a USB stick is plugged in
- » Earth fault detection on the Net Out port
- » USB host port
- » RJ45 10/100 Ethernet port for Modbus, FireMap or ASCII Text (printer/pager/nurse call) interfaces
- » RS-232 port (non-isolated) for text interface (see notes page 7)

Modbus, FireMap, and ASCII Text Interfaces

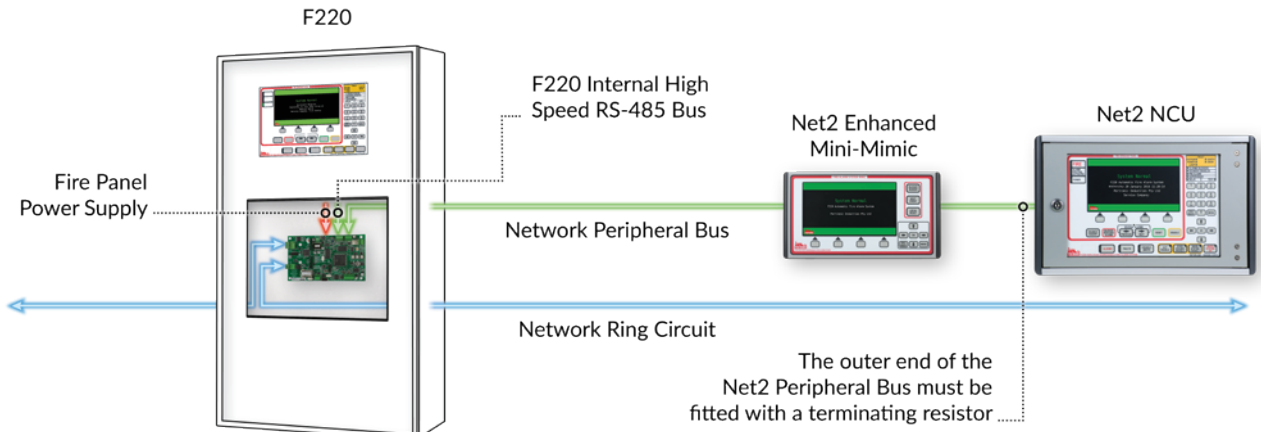

A Pertronic Net2 network node with Pertronic F220® fire panel, Net2 Enhanced Mini-Mimic, and Net2 NCU

Modbus, FireMap, and ASCII Text Interfaces

In addition to network nodes with fire panels, NCUs, and remote displays, a Pertronic F220 Net2 Network System may have the following node types.

- » Bi-Directional Modbus Node
- » Pertronic FireMap® Node
- » ASCII Text (Printer/Pager) Node

Each of these specialised nodes consists of a dedicated network card, appropriately configured in FireUtils®.

A network card may be configured to provide a bidirectional Modbus interface to a Building Management System, Plant Management System, or any other Modbus capable system, via Ethernet. User-friendly editing tools in FireUtils® make it easy to map F220 Net2 Network Nodal Mapping

Objects (NMOs) to Modbus objects.

A Net2 Network Card configured in FireUtils® as a FireMap interface will communicate with Pertronic FireMap® via an Ethernet connection.

Alternatively, a Net2 Network Card may be configured in FireUtils® to interface via Ethernet or RS-232 (see note below) with an ASCII text-based system, such as a printer, nurse call system, or paging system.

These capabilities are mutually exclusive. A single Net2 Network Card may provide a Modbus interface, a FireMap interface, a text interface, or it may connect with an F220 fire panel. However, each network card can perform only one of these functions

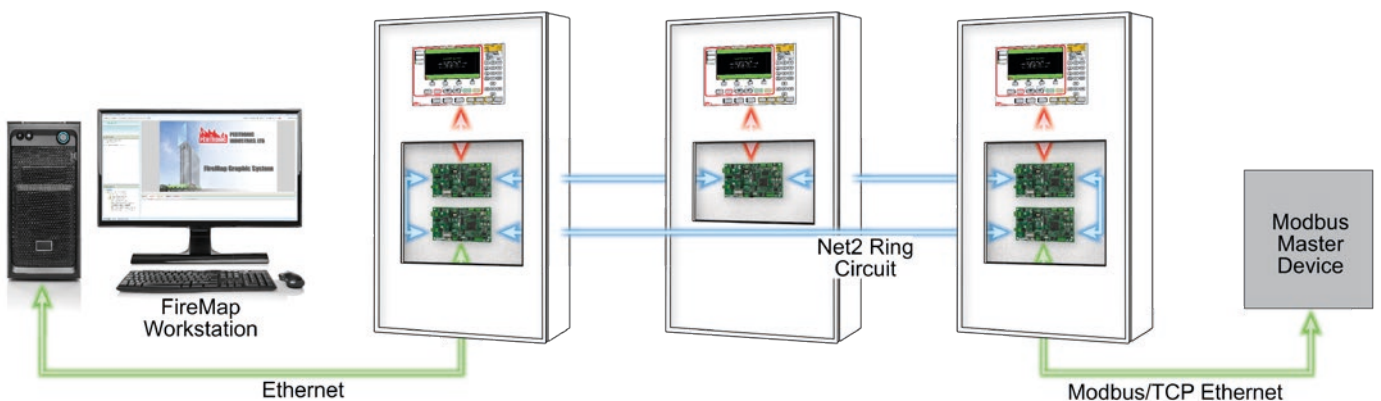

A Pertronic F220 Net2 Network System with three Pertronic F220® fire panels, one Modbus interface, and one FireMap interface

NOTES

- All RS-485 A & B (data) wires must be twisted pairs to minimise interference.
- Please note that the RS-232 port is not electrically isolated. When interfaced via RS-232 with an external system, the Net2 network card should be powered from an isolated 24 V dc power supply such as a dc to dc converter.
- On Net2 Network Cards configured as FireMap, Modbus, or ASCII Text interfaces, the Network Peripheral Bus can not be used
- To satisfy Australian regulatory requirements, each network card should be co-located with an AS 7240.4-compliant power supply. We recommend installing these cards inside a networked fire panel.

Net2 Fibre-Optic Converters

Pertronic F220 Net2 Fibre-Optic Converter (FIBNET) provide dual fibre-optic network ports for the Pertronic Net2 Network Card (NET2CARD).

Each duplex fibre-optic converter module connects one end of a fibre-optic link segment to the network card. The converter provides two connectors (“RX” and “TX”) for terminating the link segment’s dual fibre-optic cables.

The Net2 Network Card accommodates any mix of fibre-optic converters and/or RS-485 copper connections. The card has two network ports: “NET IN”, and “NET OUT”. Each port may be configured as either:

- » Copper (without fibre converter)
- » Multi-mode fibre-optic (with FIBNET-MMF or FIBNET-MMF-SC), or
- » Single-mode fibre-optic (with FIBNET-SMF or FIBNET-SMF-SC)

Converters are available for multi-mode and single-mode fibre, and are made with type ST (bayonet) or SC (push-in) connectors.

Please note that both ends of each network segment must have terminations appropriate to the cable type.



Fibre-optic converters for the Pertronic Net2 Network Card:

Above: with ST connectors
Below: with SC connectors



Configuration Options for Network Ports

The Net2 Network Card Net In and Net Out ports may be configured as single-mode or multi-mode fibre-optic ports by installing F220 Net2 Fibre-Optic (FIBNET) converters.

The FIBNET converter plugs in to a connector on the port and is retained by a mounting screw and stand-off.

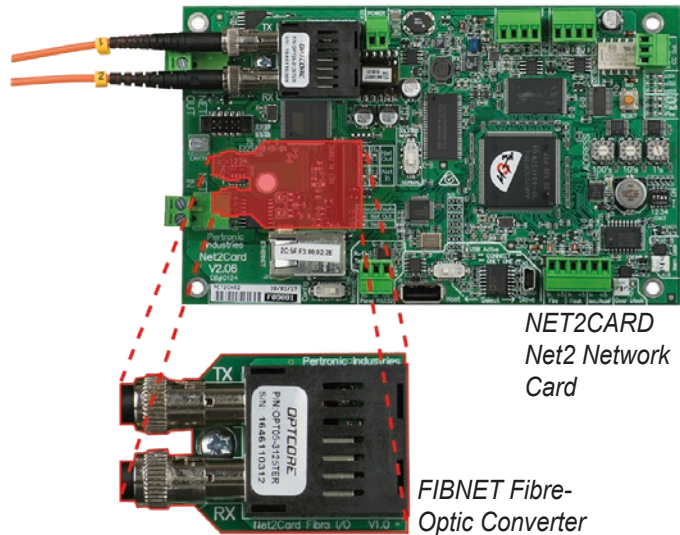

F220 Net2 Network Port Configuration Examples

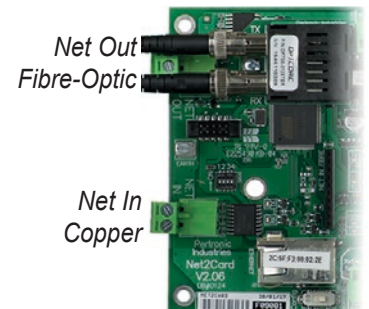
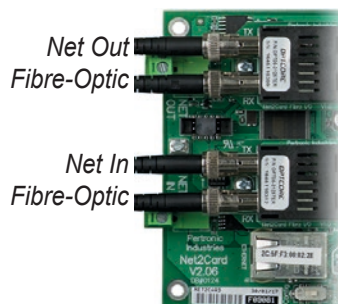
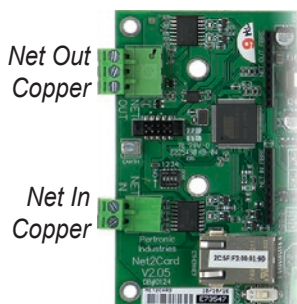

Net2 Network Layout and Operation

The Pertronic F220 Net2 Network is physically configured as a fault-tolerant bi-directional ring. This configuration provides two communication paths between any two Net2 Network Cards ("nodes"): Clockwise and Anti-Clockwise.

The ring consists of multiple segments (see diagram). Each ring segment is electrically isolated from the rest of the network. A single break or short-circuit anywhere in the ring will not disrupt network operation. This feature complies with the requirements of AS 1670.1:2018 clause 2.6.

Additional breaks or short-circuits will divide the network into isolated sub-networks, each of which will continue to function as well as may be expected in the absence of communication with other parts of the network. This feature allows node by node construction of a F220 Net2 Network. A partly-built system can be functionally tested, even though the ring circuit is not complete because some fire panels have not been connected.

Each ring segment may consist of RS-485 or dual fibre-optic cable. The segment must be a point-to-point line with no branches or spurs. Copper RS-485 segments must be wired with twisted-pair cable. For installations subject to significant electrical noise, fibre-optic cable is recommended.

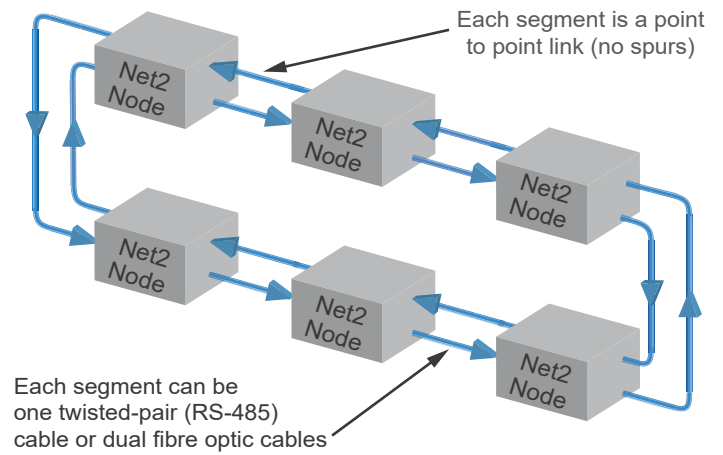

The Pertronic F220 Net2 Network is a Fault-Tolerant Bi-Directional Ring

The Pertronic Net2 product range includes optional Net2 fibre-optic converters supporting network segments up to 20 kilometres from node to node. Each fibre-optic segment has dual fibres and provides full-duplex communication (more details on page 6).

Single-Point Network Programming

A Pertronic F220 Net2 Network is easily programmed from a single location using Pertronic FireUtils®.

FireUtils® uploads a complete system configuration programme via a single password-protected network card Ethernet port. When the system configuration programme has been uploaded, the configuration files are automatically transferred to their destination devices.

One mouse-click instantly activates the new configuration programme across the network.

FireUtils® reads network details such as the firmware version installed in each device, allowing a user to check for potential problems. If any issues are identified, the existing configuration can

be imported to FireUtils® for analysis. If appropriate, the imported configuration can be modified and reloaded into the network.

Automatic Backup

Whenever a USB stick is plugged in to any network card's USB connector, the card automatically exports a complete backup which may be imported into a PC running FireUtils®.

(Please note that the network card cannot import configuration files via USB.)

FireUtils® runs on Windows 8, 10 and 11.

Please refer to the "Pertronic FireUtils®" datasheet for more information.

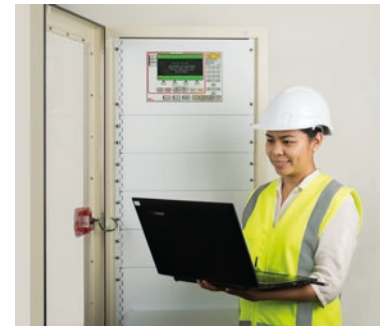

Pertronic FireUtils® workstation in use

Ordering Information

Product Code	Description	Product Code	Description
NET2CARD	Net2 Network Card		
FIBNET-MMF	Multi-mode Fibre Converter , ST Connector	FIBNET-SMF	Single-mode Fibre Converter, ST Connector
FIBNET-MMF-SC	Multi-mode Fibre Converter, SC Connector	FIBNET-SMF-SC	Single-mode Fibre Converter, SC Connector
Please refer to the "F220 & Net2 LCD Mimics" datasheet for NCU and remote display ordering information			

F220 Net2 Network Specification

Nodes per Network	Up to 160
F220 Fire Panels per Node	One
NCUs or LCD Displays per Node	Up to 8
LED Display Controllers per Node	Up to 8

Panel to Panel Object Mappings	Per Network	100,000
	Per F220 Panel	5,000
Network Inputs per Fire Panel	Directly Addressable	640
	Addressable via Logic	359
Available Zone Numbers		0 to 64,999

Net2 Network Backbone Specification

Cable Type (per Segment)	Copper, RS-485	Fibre-Optic, Multi-Mode	Fibre-Optic, Single Mode
Configuration	Twisted-Pair	Dual Fibre	Dual Fibre
Transmission Mode	Half-Duplex	Full-Duplex	Full-Duplex
Max. Segment Length Node to Node	1 km	2 km	20 km
Network Data Rate	230.4 kbit/s	230.4 kbit/s	230.4 kbit/s

Net2 Network Card (NET2CARD) Specification

Supply Voltage	18 to 30 V dc	
Standby Current, excl. Peripheral Bus	45 mA	
Operating Current	2 Copper Ports	75 mA
	1 Copper, 1 Fibre	90 mA
	2 Fibre Ports	105 mA
Peripheral Bus Current	175 mA (maximum)	
Peripheral Bus Data Rate (RS-485)	115.2 kbit/s	
Ethernet Data Rate	100 Mbit/s (maximum)	
Ethernet Connection	RJ45 10/100	
Network Connections	Copper (RS-485)	Screw terminals, 0.5 to 2.5 mm ² stranded
	Fibre-Optic	ST or SC
Other Connectors (Screw Terminals)	0.2 to 1.5 mm ² stranded	
Weight	124 g	
Dimensions (W x H x D)	167 x 101 x 23 mm	
Operating Temperature	-10 °C to +50 °C	
Relative Humidity	≤ 95 % non-condensing	

Modbus Protocol	Modbus/TCP	
Modbus Data Rate	100 Mbit/s (maximum)	
Modbus Objects	Any combination of coils, discrete inputs, holding registers, and input registers, up to a total of 3000 bits. (Each register can hold up to 16 NMOs)	
Nodal Mapping Objects (Boolean)	3000	
Modbus/FireMap IP Address	Configurable	
Modbus/FireMap/Text IP Port	Configurable	
ASCII Text Interface (Note 4)	Output	TCP/IP (Client or Server), UDP (Client), Serial (RS-232)
	Data Rate	300 bit/s to 230,400 bit/s
	Parity	None, Even, Odd, Mark & Space
	Char Length	7 to 8 bits per character
	Stop Bits	1, 1.5, or 2

Net2 Fibre-Optic Converter (FIBNET) Specification

	Fibre Type		Notes
	Multi-Mode	Single-Mode	
Fibre Size	50/125 or 62.5/125 µm	9/125 µm	
Wavelength	1310 nm (1260 – 1360 nm)		
Tx Power	-3 to -9 dBm		
Rx Sensitivity	-16 dBm	-20 dBm	The optical power arriving at the receiver must be greater than the specified Rx Sensitivity, and less than the specified Rx Overload. To satisfy this requirement it may be necessary to fit an attenuator.
Rx Overload	-3 dBm		
Link Budget	7 dB	11 dB	Maximum allowable end-to-end link attenuation.

This information must not be treated as partial or complete instructions for the design, construction, installation, commissioning, or maintenance of fire detection, fire alarm, or building evacuation systems. Fire and evacuation systems must be designed and installed by properly qualified persons, in accordance with all applicable regulatory requirements.

Unless explicitly stated otherwise, this document provides typical specifications and nominal dimensions. Actual product performance and dimensions may vary.

All information in this document is subject to change. Please consult Pertronic Industries or visit our web site for up to date information.

FIREUTILS®, PERTRONIC®, PERTRONIC FIREMAP®, PERTRONIC F220® are registered trademarks of Pertronic Industries Limited.

