

PERTRONIC INDUSTRIES LTD

DATASHEET

Analogue Addressable Loop Relay

AALREL (F100LRU)



Analogue addressable output module with four output channels

Each channel has a voltage-free contact and a supervised 24 V dc output

Each channel is independently addressable by the fire panel

Overview

The **Pertronic Analogue Addressable Loop Relay** provides four individually addressable output channels, controlled over an analogue addressable circuit (loop) by a Pertronic fire panel such as the Pertronic F220 or F100A.

Each output channel provides:

- » A switched, supervised output providing 24 volts dc when activated, and
- » A voltage-free relay contact

On each output channel, the supervised output and the voltage-free contact are activated simultaneously.

The supervised 24 volt dc output may be powered from the analogue addressable loop or from an external power supply. The load circuit connected to this output is supervised for short-circuit and open-circuit wiring faults.

The voltage-free relay contacts may be individually configured as normally open or normally closed.

The loop relay has two configurable output settings. When configured for “steady-only” operation, each active output stays on until de-activated by the fire panel. With pulsing enabled, the fire panel can activate each individual output



Pertronic Analogue Addressable Loop Relay

in steady or pulsing mode (3.5 sec on, 12.5 sec off).

The loop relay has a built-in isolator. If the loop relay detects a short-circuit in the signalling circuit (loop) cable, the isolator disconnects the shorted segment. This ensures that the loop relay continues to communicate with the fire panel over the undamaged side of the loop circuit.

A single short-circuit or open-circuit fault will not prevent correct operation of the loop relay.

Features

- » Analogue addressable control module with four individually addressable output channels
- » Each output channel provides:
 - » One voltage-free relay contact, configurable as normally open or normally closed, and
 - » One switched supervised output providing 24 volt dc at up to 100 mA (loop powered) or 1 amp (externally powered)
- » Solenoid interface available for supervising external cabling to solenoids and similar loads
- » Up to 24 AA Loop Relays (a total of 96 outputs) may be connected to a Pertronic analogue addressable loop, subject to availability of power
- » The loop relay may be powered from the analogue addressable signalling line circuit (loop) or from an external isolated power supply
- » The integral short circuit isolator maintains normal operation with a single break or short-circuit in the analogue addressable loop
- » The loop address is programmed with direct-dial decade address switches
- » The loop relay is able to report the following fault types to the fire panel:
 - » Isolator activation
 - » Loss of external power supply
 - » An open circuit on the PS Fault input
 - » A short circuit or open circuit on any of the four supervised outputs, when that output channel is inactive
- » Configurable output modes:
 - » All outputs steady (continuous) activation only
 - » Each output may be steady or pulsing (on-off)
- » The loop relay uses four loop addresses when configured in steady mode, or eight loop addresses when pulsing mode is enabled
- » The loop relay is an optional component of Pertronic analogue addressable fire panels
- » The loop relay may be mounted remote from the fire panel. For this purpose the Pertronic AALRESC enclosure accommodates two loop relay modules
- » FPANZ listing number PI/634

Specification: Loop Relay

Operating Voltage	15 to 30 V dc (loop-powered)	Loop Addresses	Steady-Only	Four
Quiescent Current	6 mA @ 24 V dc		Pulsing Enabled	Eight
PCB Dimensions	97 x 138 x 24 mm (H x W x D)	Relay Contacts (each)	2.0 A @ 30 V dc, nc or no	
Operating Temperature	-10 °C to +50 °C	Supervised Outputs (each)	Loop Powered	100 mA*
Humidity	≤ 95% RH, non-condensing		Ext. Powered	1 A @ 24 V dc
			End of Line	10 kΩ resistor

* The total current drawn from a Pertronic AA loop, including loop relay outputs and all other connected loop devices, must not exceed 350 mA.

Specification: Loop Responder / Relay Case

Dimensions	310 mm x 255 mm x 90 mm (W x H x D)
Material	0.8 mm mild steel, powder-coated
Weight	1.6 kg
Colour	Off-white (Dulux 915 58804)

Typical Connections

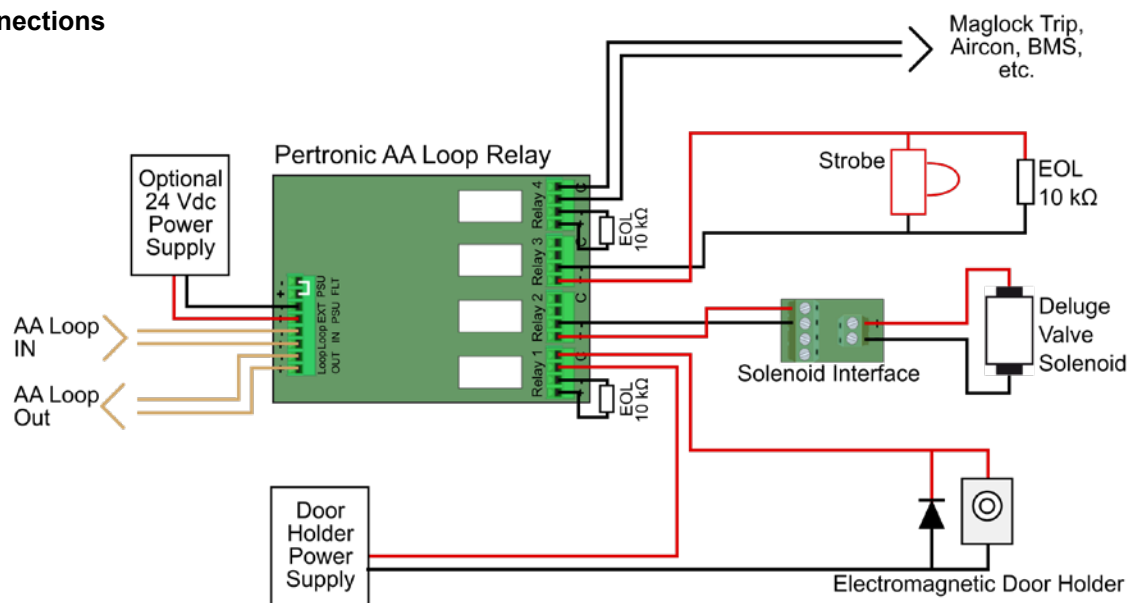

Above: Typical applications for the Pertronic Analogue Addressable Loop Relay.

Output 4: Relay contact switching a maglock trip, or an input to an air-conditioning system, BMS, or other device.

Output 3: Supervised output driving a “conventional” (dc operated) strobe.

Output 2: Supervised output driving a deluge valve solenoid via a Pertronic solenoid interface. In this application, the loop relay will detect open-circuit faults including a disconnected or open-circuit solenoid. The loop relay will also identify a short-circuit fault in the cabling between control module and solenoid interface, but not a short-circuit across the solenoid itself. The solenoid interface includes back emf protection.

Output 1: Relay contact controlling an electromagnetic door holder. This output is not supervised for faults. Note back emf diode due to inductive load.

Notes:

- DO NOT use the AA loop relay for controlling gas discharge suppression systems. We recommend the Pertronic Agent Release Controller (AGENTRELEASEC) and Pertronic Agent Release Control Panels for gas suppression control. Please refer to the Pertronic website for details.
- A Pertronic solenoid interface (such as ARCSI, BUR-2509-10K, or HIR-GDM-10K) must be used when driving a solenoid or electrically similar device from any of the supervised outputs. The loop relay will show a permanent short circuit fault if a solenoid is connected directly to a supervised output. Please refer to the Pertronic website for details of Pertronic solenoid interfaces
- The loop relay will not activate an output if there is a short-circuit on the associated supervised voltage circuit. Each output should control one circuit only, using the supervised output or the voltage-free contact, but not both.

Ordering Information

Product Code (Outside of NZ & Fiji)	Description
AALREL	Analogue Addressable Loop Relay with Four Relays
AALRESC	Case for AA Loop Responder & AA Loop Relay
Product Code (NZ & Fiji)	Description
F100LRU	Analogue Addressable Loop Relay with Four Relays
F100LRC	Case for AA Loop Responder & AA Loop Relay

This information must not be treated as partial or complete instructions for the design, construction, installation, commissioning, or maintenance of fire detection, fire alarm, or building evacuation systems. Fire and evacuation systems must be designed and installed by properly qualified persons, in accordance with all regulatory requirements. Unless explicitly stated otherwise, this document provides typical specifications and nominal dimensions. Actual product performance and dimensions may vary. All information in this document is subject to change. Please consult Pertronic Industries or visit our web site for up to date information.

PERTRONIC® is a registered trademark of Pertronic Industries Limited.

