



## Description

The VESDA VLC is made up of two parts: the main enclosure and the front cover.

The main enclosure houses all the key components of the detector. All non-serviceable items like the main processor board and detector chamber are mounted away from the general access area, protecting them during the installation and service process.

The front cover includes:

- 5 LEDs: Fire, Pre-Alarm/Alert, Fault, OK, Reset/Isolate
- Reset/Isolate Push Button (press to reset, press and hold to isolate)

## Listings / Approvals

- DNV Type Approval certificate: A-13709.
- DNV Location classes:
  - Temperature (D), Humidity (B), Vibration (A), Electromagnetic Compatibility (B), Ingress protection (IP30) or (IP66) with optional enclosure.
  - Environmental tests have been performed according to Lloyd's Register Specification 1 (2002) for environmental categories ENV1, ENV2, and ENV3.

## Introduction

The VESDA VLC detector has been tested and certified to provide all the benefits of aspirating smoke detection, including very early warning, in Marine Environments. This has been achieved through additional testing to ensure the performance of the product in challenging marine applications.

The Marine products are approved by Det Norske Veritas (DNV). They are rated IP30 so, in locations where higher IP protection is required, the detector should be housed in an IP66 enclosure (available from Xtralis). The detectors can be installed in the following location classes:

Parameters	Locations within the main area	Machinery spaces	Control rooms accommodations	Bridges	Pump rooms Holds Rooms with no heating	Open Decks
Temperature	Inside cubicles, desks, etc. With temperature rise of 5°C or more	✓	✓	✓	✓	✓
	All other locations	✓	✓	✓	✓	✓
Humidity	Locations where special precautions are taken to avoid condensation	✓	✓	✓	✓	✓
	All other locations	✓	✓	✓	✓	✓
Vibration	On machinery such as internal combustion engines, compressors, pumps, including piping on such machinery	✗	-	-	✗	✗
	Masts	-	-	-	-	✗
	All other locations	✓	✓	✓	✓	✓
EMC	All locations within specified main areas	✓	✓	✓	✓	✓
Enclosure	Submerged application	✗	-	-	✗	✗
	Below floorplates in engine room	✗	-	-	-	-
	All other locations	✓	✓	✓	✓	✗

As with the standard VESDA VLC, the Marine version combines the well-proven VESDA Laser detection technology, dual-stage air filtration technology and a reliable aspirator design, and incorporates them into a compact enclosure with a simplified display.

## Two variants and a remote display option

The Marine version of the VESDA VLC is available in two versions, one that interfaces via relays only (RO) and one that interfaces via relays and VESDAnet (VN).

The VN version is compatible with the Marine version of the remote Display Module, which allows the current status of the detector to be reported in the most convenient location (such as the bridge). The remote Display Module has 7 remote relays to support any combination of signalling that may be demanded by the application. The VN version also allows several detectors to be linked together on VESDAnet thereby allowing one to act as a reference detector for other VESDA detectors.

## How it works

Air is continually drawn through holes and a simple pipe network to a central detector by a high efficiency aspirator. Air entering the unit passes a flow sensor before a sample is passed through a dual-stage dust filter (the majority of air is exhausted from the detector and can be back vented to the protected area when required). The first stage removes dust and dirt from the air sample before it enters the chamber for smoke detection. The second ultra fine stage provides a clean air supply to be used inside the detection chamber to form clean air barriers, which protect the optical surfaces from contamination.

The detection chamber uses a stable, highly efficient laser light source and unique sensor configuration to achieve the optimum response to a wide range of smoke types. When smoke passes through the detection chamber it creates light scatter which is detected by the very sensitive sensor circuitry.

The status of the detector, all alarms, service and fault events, are monitored and logged with time and date stamps. Status reporting can be transmitted via simple relay connections or across the advanced VESDAnet communications network (VN version only).

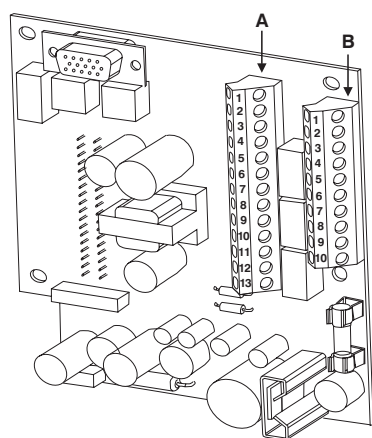

### VESDA VLC Termination Card (VN)

Terminal A	Terminal B
1 Bias (-) (GND)	1 Shield
2 Reset (-)	2 VESDAnet-A (-)
3 Reset (+)	3 VESDAnet-A (+)
4 Bias (+)	4 Shield
5 LED (-) (GND)	5 VESDAnet-B (-)
6 LED (+)	6 VESDAnet-B (+)
7 FIRE (NO)	7 Power (-)
8 FIRE (C)	8 Power (+)
9 PRE-ALARM (NO)	9 Power (-)
10 PRE-ALARM (C)	10 Power (+)
11 FAULT (NO)	
12 FAULT (C)	
13 FAULT (NC)	

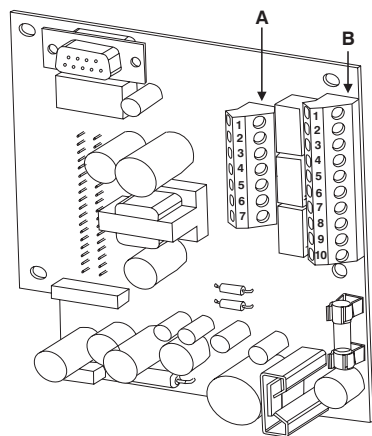

### VESDA VLC Termination Card (RO)

Terminal A	Terminal B
1 FIRE (NO)	1 Bias (-) (GND)
2 FIRE (C)	2 Reset (-)
3 PRE-ALARM (NO)	3 Reset (+)
4 PRE-ALARM (C)	4 Bias (+)
5 FAULT (NO)	5 LED (-) (GND)
6 FAULT (C)	6 LED (+)
7 FAULT (NC)	7 Power (-)
	8 Power (+)
	9 Power (-)
	10 Power (+)

## Ordering Information

**Product**  
VESDA VLC – Marine VN  
VESDA VLC – Marine RO  
Remote Display – VESDA VLC Marine  
IP66 Detector Enclosure (incl fittings)

**Part number**  
VLC-5050-MRN  
VLC-5000-MRN  
VRT-J0000-MRN  
020-050

www.xtralis.com

UK and Europe +44 1442 242 330 D-A-CH +49 431 23284 1 The Americas +1 781 740 2223  
Middle East +962 6 588 5622 Asia +86 21 5240 0077 Australia and New Zealand +61 3 9936 7000

The contents of this document are provided on an "as is" basis. No representation or warranty (either express or implied) is made as to the completeness, accuracy or reliability of the contents of this document. The manufacturer reserves the right to change designs or specifications without obligation and without further notice. Except as otherwise provided, all warranties, express or implied, including without limitation any implied warranties of merchantability and fitness for a particular purpose are expressly excluded.

Xtralis, the Xtralis logo, The Sooner You Know, VESDA-E, VESDA, ICAM, ECO, OSID, HeiTel, ADPRO, IntrusionTrace, LoiterTrace, ClientTrace, SmokeTrace, XQa, XOh, iTrace, iCommand, iRespond, iCommission, iPIR, and FMST are trademarks and/or registered trademarks of Xtralis and/or its subsidiaries in the United States and/or other countries. Other brand names mentioned herein are for identification purposes only and may be trademarks of their respective holder(s). Your use of this document does not constitute or create a licence or any other right to use the name and/or trademark and/or label.

This document is subject to copyright owned by Xtralis. You agree not to copy, communicate to the public, adapt, distribute, transfer, sell, modify or publish any contents of this document without the express prior written consent of Xtralis.

Part: 30129

## Specifications

### Supply voltage:

18 to 30VDC

### Power consumption:

5.4W quiescent, 5.9W with alarm

### Current consumption:

225mA quiescent, 245mA with alarm

### Fuse rating:

1.6A

### Dimensions (WHD):

225mm x 225mm x 85mm (8 7/8" x 8 7/8" x 3 3/8")

### Weight:

1.9kg (4.2lbs.)

### Operating conditions:

Tested to -25°C to 70°C (-13°F to 158°F)

Ambient 5°C to 70°C (41°F to 158°F) (recommended)

Sampled Air -20°C to 60°C (-4°F to 140°F)

Humidity 10 to 95% RH, non-condensing

Approved for use in bridge and deck zones, and ENV3 environments

Exposure to corrosive atmosphere may invalidate warranty

### Sampling network:

Maximum area of Coverage 800sq.m (8000sq.ft)

### Maximum pipe lengths:

1 x 80m, 2 x 50m

### Computer design tool:

ASPIRE2™

### Pipe:

Internal Diameter 15–21mm (9/16"–7/8")

External Diameter 25mm (1")

### Relays:

3 Relays rated 2A @ 30VDC

Fire (NO)

Pre-Alarm (NO)

Alert/Fault (Maintenance & Isolate) (NC/NO)

Configurable as latching or non-latching

### IP rating:

IP30 (optional IP66 enclosure)

### Cable access:

4 x 25mm (1") cable entries

### Cable termination:

Screw Terminal blocks 0.2-2.5sq mm (30-12 AWG)

### Sensitivity range:

0.005 to 20% obs/m (0.0015 to 6.25% obs/ft)

### Threshold setting range:

Alert: 0.005–1.990% obs/m  
(0.0015–0.6218% obs/ft)

Pre-Alarm: 0.010–1.995% obs/m  
(0.0031–0.6234% obs/ft)

Fire: 0.015–20.00% obs/m  
(0.0046–6.25% obs/ft)

### Software features:

Event log: Up to 12,000 events stored on FIFO

Smoke level, alarms and faults with time and date stamp

AutoLearn: Minimum 15 minutes, maximum 15 days.

Recommended minimum 1 day.

During AutoLearn thresholds are NOT changed from pre-set values.

### Configurable general input (24VDC):

Standby, Mains OK or Reset/Isolate