



# 2251BPI and 2251TMBPI Intelligent Photoelectric Smoke Sensors

[www.pertronic.co.nz](http://www.pertronic.co.nz)  
[www.pertronic.com.au](http://www.pertronic.com.au)

## SPECIFICATIONS

Operating Voltage Range:	15VDC to 32VDC
Max. Avg. Standby Current:	360µA @ 24 VDC (one communication every 5 seconds with LED blink enabled)
Max. Alarm Current (LED on):	6.5 mA @ 24 VDC
Operating Humidity Range:	10% to 93% Relative Humidity, Non-condensing
Operating Temperature Range:	-10°C to 49°C
Height:	51 mm installed in B501 base
Diameter:	104 mm installed in B501 base
Weight:	147 g
Fixed Temperature Rating:	63°C; 2251TMBPI

Before installing and using the product, please read the system wiring and installation manual thoroughly. If the products will be installed in an existing operational system, inform the operator and local authority that the system will be temporarily out of service, disconnect power to the control panel before installing the products.

This sensor must be connected to a compatible Pertronic Industries C.I.E. in accordance with the system installation manual. The installation must meet the requirements of the Authority Having Jurisdiction (AHJ). Sensors offer maximum performance when installed in compliance with AS1670.1-2004 or NZS4512.

NOTICE: This manual should be left with the owner/user of this equipment.

## GENERAL DESCRIPTION

Models 2251BPI and 2251TMBPI are plug-in type smoke sensors that combine a photoelectric sensing chamber with addressable-analog communications. The sensors transmit an analog representation of smoke density over a communication line to a control panel. These sensors also have an integrated drift compensation feature which automatically adjusts the sensitivity response to compensate for a slow build-up of contamination within the sensing chamber. Rotary-decade switches are provided for setting the sensor's address.

Two LEDs on the sensor are controlled by the panel to indicate sensor status. An output is provided for connection to an optional remote LED annunciator.

Model 2251TMBPI combines a photoelectric sensing chamber and 146°F (63°C) fixed temperature heat detector.

The 2251BPI and 2251TMBPI require compatible addressable communications to function properly. Connect these sensors to listed-compatible control panels only.

## SPACING

Pertronic recommends spacing sensors in compliance with AS1670.1-2004 or NZS4512. All detectors should be spaced and installed in accordance with the requirements of the relevant authority having jurisdiction. For specific information regarding sensor spacing, placement and special applications, refer to AS1670.1-2004 or NZS4512 or the "System Smoke Detectors" Application Guide, available from Pertronic Industries. Duct Applications: Model 2251BPI is listed for use inside the DNR-AUS duct sampling smoke detector.

## WIRING GUIDE

All wiring must be installed in compliance with the National Electrical Code, applicable local codes, and any special requirements of the Authority Having Jurisdiction. Proper wire gauges should be used. The installation wires should be color-coded to limit wiring mistakes and ease system troubleshooting. Improper connections will prevent a system from responding properly in the event of a fire.

Remove power from the communication line before installing sensors.

1. Wire the sensor base (supplied separately) per the wiring diagram, Figure 1.
2. Set the desired address on the sensor address switches, see Figure 2.
3. Install the sensor into the sensor base. Push the sensor into the base while turning it clockwise to secure it in place.
4. After all sensors have been installed, apply power to the control unit and activate the communication line.
5. Test the sensor(s) as described in the TESTING section of this manual.



Dust covers provide limited protection against airborne dust particles during shipping. Dust covers must be removed before the detectors can sense smoke. Remove detectors prior to heavy remodeling or construction.

FIGURE 1. WIRING DIAGRAM

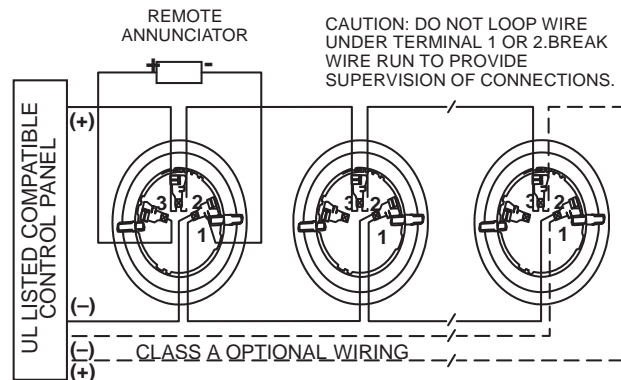

FIGURE 2. ROTARY ADDRESS SWITCHES

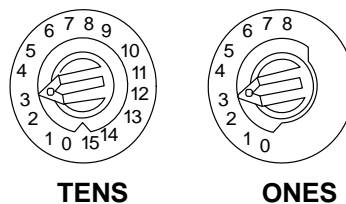
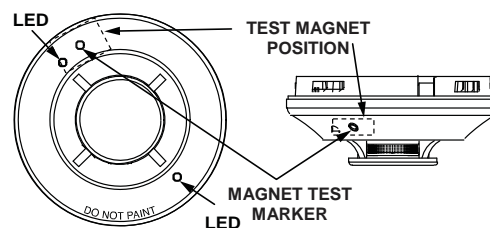

FIGURE 3. TEST MAGNET POSITION



## TAMPER-RESISTANCE

Models 2251BPI and 2251TMBPI include a tamper-resistant capability that prevents their removal from the bracket without the use of a tool. Refer to the base manual for details on making use of this capability.

## TESTING

Before testing, notify the proper authorities that the smoke detector system is undergoing maintenance, and that it will be temporarily out of service. Disable the zone or system under-going maintenance to prevent unwanted alarms.

All sensors must be tested after installation and periodically thereafter. Testing methods must satisfy the Authority Having Jurisdiction (AHJ). Sensors offer maximum performance when tested and maintained in compliance with AS1670.1-2004 or NZS4512.

These sensors can be tested in the following ways:

### A. Functional: Magnet Test (P/N M02-04-01 or M02-09-00)

This sensor can be functionally tested with a test magnet. The test magnet electronically simulates smoke in the sensing chamber, testing the sensor electronics and connections to the control panel.

1. Hold the test magnet in the magnet test area as shown in Figure 3.
2. The sensor should alarm the panel.

Two LEDs on the sensor are controlled by the panel to indicate sensor status. Coded signals, transmitted from the panel, can cause the LEDs to blink, latch on, or latch off. Refer to the control panel technical documentation for sensor LED status operation and expected delay to alarm.

**B. Smoke Entry: Aerosol Generator (Gemini 501)**

The GEMINI model 501 aerosol generator can be used for smoke entry testing. Set the generator to represent 4%/ft to 5%/ft obscuration as described in the GEMINI 501 manual. Using the bowl shaped applicator, apply aerosol until the panel alarms. Additionally, canned aerosol simulated smoke (canned smoke agent) may be used for smoke entry testing of the smoke detector. Tested and approved aerosol smoke products are the Smoke Detector Tester model 25S available from Home Safeguard Industries and Chekkit Smoke Detector Tester models CHEK02 and CHEK06 available from SDi. When used properly, the canned smoke agent will cause the smoke detector to go into alarm. Refer to the manufacturer’s published instructions for proper use of the canned smoke agent.



Canned aerosol simulated smoke (canned smoke agent) formulas will vary by manufacturer. Misuse or overuse of these products may have long term adverse effects on the smoke detector. Consult the canned smoke agent manufacturer’s published instructions for any further warnings or caution statements.

For 2251TMBPI, smoke entry testing should be performed immediately following the magnet test. Magnet test initiates an approximately 10 minute period when the detector’s signal processing software routines are not active. Failure to first perform the magnet test will introduce a time delay before the detector alarms.

**C. Direct Heat Method (Hair Dryer of 1000-1500 watts) 2251TMBPI only**

A hair dryer of 1000-1500 watts should be used to test the thermistors. Direct the heat toward either of the two thermistors, holding the heat source approximately 12 inches from the detector in order to avoid damaging the plastic housing. The detector will reset only after it has had sufficient time to cool. Make sure both thermistors are tested individually.

A sensor that fails any of these tests should be cleaned as described under CLEANING, and retested. If the sensor fails after cleaning, it must be replaced. When testing is complete, restore the system to normal operation and notify the proper authorities that the system is back in operation.

**CLEANING**

Before removing the detector, notify the proper authorities that the smoke detector system is undergoing maintenance and will be temporarily out of service. Disable the zone or system undergoing maintenance to prevent un-wanted alarms.

1. Remove the sensor to be cleaned from the system.
2. Remove the sensor cover by pressing firmly on each of the four removal tabs that hold the cover in place.
3. Vacuum the screen carefully without removing it. If further cleaning is required continue with Step 4, otherwise skip to Step 7.
4. Remove the chamber cover/screen assembly by pulling it straight out.
5. Use a vacuum cleaner or compressed air to remove dust and debris from the sensing chamber
6. Reinstall the chamber cover/screen assembly by sliding the edge over the sensing chamber. Turn until it is firmly in place.
7. Replace the cover using the LEDs to align the cover and then gently pushing it until it locks into place. Make sure that the thermistors do not become bent under the cover on 2251TMBPI model.
8. Reinstall the detector.
9. Test the detector as described in TESTING.
10. Reconnect disabled circuits.
11. Notify the proper authorities that the system is back on line.

Note: Please dispose electronic waste following national or local regulations after being scrapped or replaced. Do not discard.

**FIGURE 4. SENSOR ASSEMBLY**

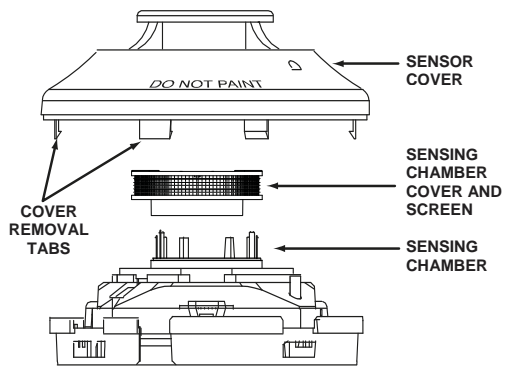

**SPECIAL NOTE REGARDING SMOKE DETECTOR GUARDS**

Smoke detectors are not to be used with detector guards unless the combination has been evaluated and found suitable for that purpose.



**SYSTEM  
SENSOR®**

**FCC Statement**

This device complies with part 15 of the FCC Rules. Operation is subject to the following two conditions: (1) This device may not cause harmful interference, and (2) this device must accept any interference received, including interference that may cause undesired operation.

Note: This equipment has been tested and found to comply with the limits for a Class B digital devices, pursuant to Part 15 of the FCC Rules, These limits are designed to provide reasonable protection against harmful interference in a residential installation. This equipment generates, uses and can radiate radio frequency energy and, if not installed and used in accordance with the instructions, may cause harmful interference to radio communications. However, there is no guarantee that interference will not occur in a particular installation, If this equipment does cause harmful interference to radio or television reception, which can be determined by turning the equipment off and on, the user is encouraged to try to correct the interference by one or more of the following measures:

- Reorient or relocate the receiving measures.
- Increase the separation between the equipment and receiver.
- Connect the equipment into an outlet on a circuit different from that to which the receiver is connected.
- Consult the dealer or an experienced radio/TV technician for help.

**THREE-YEAR LIMITED WARRANTY**

Pertronic Industries warrants its enclosed smoke detector to be free from defects in materials and workman-ship under normal use and service for a period of three years from date of manufacture. Pertronic Industries makes no other express warranty for this smoke detector. No agent, representative, dealer, or employee of the Company has the authority to increase or alter the obligations or limitations of this Warranty. The Company’s obligation of this Warranty shall be limited to the repair or replacement of any part of the smoke detector which is found to be defective in materials or workmanship under normal use and service during the three year period commencing with the date of manufacture. After contacting your local Pertronic Industries representative for issuing a Return Authorization number (RA#) and arrange for return

Return of the defective units. Please include a note describing the malfunction and suspected cause of failure. The Company shall not be obligated to repair or replace units which are found to be defective because of damage, unreasonable use, modifications, or alterations occurring after the date of manufacture. In no case shall the Company be liable for any consequential or incidental damages for breach of this or any other Warranty, expressed or implied whatsoever, even if the loss or damage is caused by the Company’s negligence or fault. Some states do not allow the exclusion or limitation of incidental or consequential damages, so the above limitation or exclusion may not apply to you. This Warranty gives you specific legal rights, and you may also have other rights which vary from state to state.