

Aspirating Smoke Detector Pipe Installation

USER GUIDE

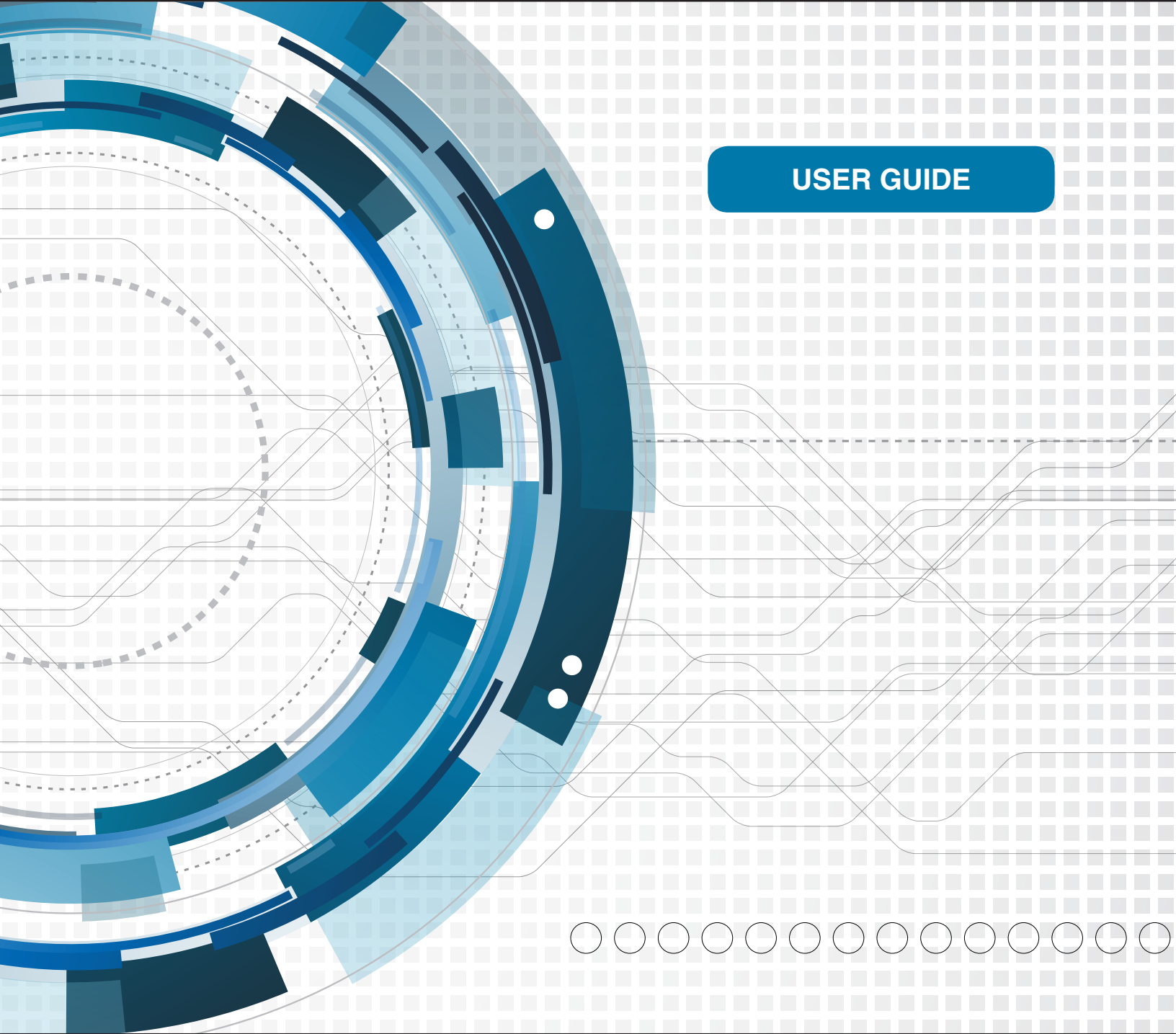

Table of Contents

| | | | |
|---|----------|---|-----------|
| Scope of this user guide..... | 3 | Sampling Methods..... | 11 |
| Designing a Pipe Network | 3 | Standard Pipe Network Sampling | 11 |
| Pipe Overview | 4 | Capillary Tube Sampling | 11 |
| Pipe Network Components..... | 4 | Open Area Protection | 12 |
| Pipes | 4 | Ceiling Sampling | 12 |
| Pipe Temperature..... | 4 | Inter-Beam / Below-Beam Sampling | 13 |
| Fittings..... | 4 | Under Floor Protection..... | 13 |
| Couplings and Unions..... | 4 | Floor Void Sampling..... | 13 |
| Elbows | 4 | Object Protection..... | 14 |
| Tees..... | 4 | Cabinet Sampling | 14 |
| End Caps..... | 5 | In-Cabinet Sampling..... | 14 |
| Capillary Tubes and Sampling Ports..... | 5 | Above-Cabinet Sampling | 14 |
| Mounting Brackets..... | 5 | Large Area Protection | 15 |
| Labels | 5 | Cold Area Protection | 15 |
| Pipe Network Installation..... | 6 | High Air Exchange Areas | 16 |
| Cutting Pipe | 6 | Return Air Sampling..... | 16 |
| Joining Components..... | 6 | In-Duct Sampling..... | 17 |
| Mounting the Pipe Network | 6 | Design Considerations for In-Duct Sampling..... | 17 |
| Pipe Bends | 6 | Small Duct Sampling | 17 |
| Drilling Sample Ports | 7 | Large Duct Sampling..... | 18 |
| Installation Stages..... | 7 | Port Orientation | 18 |
| Application and Design..... | 8 | Monitoring Voids..... | 18 |
| Design..... | 8 | Basic Pipe Cleaning & Maintenance..... | 19 |
| Regulatory Requirements | 9 | Pipe Network Maintenance | 19 |
| Site Layouts and Measurements | 10 | Filter Maintenance | 19 |
| Site Details | 10 | | |
| Environmental Conditions..... | 10 | | |
| System Design..... | 10 | | |

Scope of this user guide

The purpose of this user guide is to provide details on the physical installation of the pipe network for the FAAST Fire Alarm Aspiration Sensing Technology® aspirating smoke detector. Local codes and regulations may vary and take precedence over the information contained in this user guide.

Designing a Pipe Network

The FAAST detector and its pipe network allow deployment of smoke detection in challenging and mission critical environments. In order to ensure the system will operate in accordance to site specific requirements, as well as local codes and regulations, the pipe network must be designed and verified using the PipeIQ® software. PipeIQ can be downloaded at systemsensor.com/faast.

Pipe Overview

Pipe Network Components

The FAAST detector uses standard aspiration fire detection pipe network components, such as pipes, elbows and couplings. The components listed in this section are not an all inclusive list, however they represent the most commonly used items.

Pipes

The pipes used in the pipe network can be made of various materials including copper, PVC, ABS, UPVC and CPVC. The internal pipe diameter used with the FAAST system can range from 0.591" to 0.827" (15 to 21 mm). Ideal dimensions vary depending on system design requirements as well as local codes and regulations. The FAAST detector has a built in tiered insertion point for the pipes which allows for an outside tube diameter of either 1.050" or 25 mm to accommodate U.S. Customary System and Metric System Sized Pipes.

Frequently Asked Question – Can we use metal pipe instead of plastic with FAAST?

Yes. It is acceptable to use either steel or copper pipe under the following conditions:

- The pipe size used must be capable of fitting to a plastic pipe upon interfacing with the FAAST device. The inner diameter must be within the approved range of .591" - .827" (15.00 - 21.00 mm).
- The material must be approved by the local authority having jurisdiction and must also be approved by the insurance underwriter

Pipe Temperature

Pipe selection may be contingent on the temperature of the room in which the pipe will be mounted. Table 1 shows temperature ranges for various types of pipe.

| Pipe Material | Service Temperature |
|---------------|-------------------------------|
| ABS | -40 – 80°C (-40 to 176°F) |
| PE-80 | -50 to 60°C (-58 to 140°F) |
| PE-100 | -50 to 60°C (-58 to 140°F) |
| CPVC | -26 to 93°C (-15 to 200°F) |
| PVC | -26 to 49°C (-15 to 120°F) |
| Copper | -150 to 110°C (-238 to 230°F) |

Table 1: Temperature ranges for various types of pipe.

* For specific design considerations in cold temperature applications, download the Cold Storage White Paper from systemsensor.com/faast

Fittings

Fittings are used to connect sections of pipe together on longer network runs and are made from the same material as the pipe. There are several types of fittings to allow for various bends, straight runs, branches and connections. Common fittings are described in the following sections.

Couplings and Unions

Couplings and unions are used to connect two sections of pipe in a straight line. A coupling is used when the section is not intended to be taken apart.

A union offers the ability to screw the two pipe sections together for future access, such as areas of the pipe network that have to be periodically disassembled for maintenance and cleaning. Unions can also be used to orient sample ports correctly in a specific section of the pipe network, such as over return air grilles (for more information on high air flow and duct applications, see the white paper at systemsensor.com/faast). Figure 1 shows a typical union and coupling.

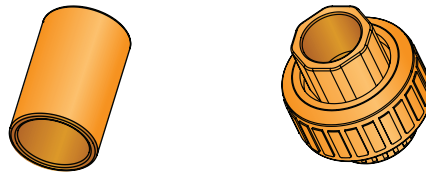

Figure 1: Couplings and unions.

Elbows

Elbows are used to change the direction of the pipe network. Both 45 degree and 90 degree elbows may be used. Both elbow fittings are shown in figure 2.

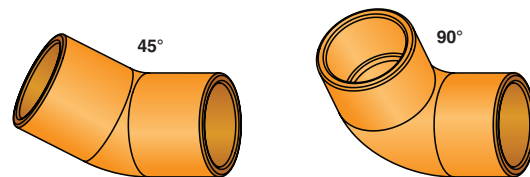

Figure 2: Elbows.

Tees

Tees are also used for branching into multiple pipes from a single pipe network. A specialized tee can be used to attach a capillary tube and a sampling port. A tee is shown in figure 3.

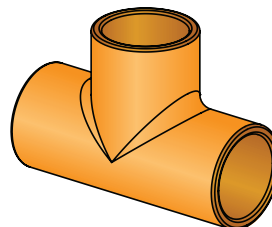

Figure 3: Tees

End Caps

The end of the pipe should be terminated with an end cap. The end cap may have a sampling port depending on the system design. The size of the port in the end cap is determined by the PipelQ software. An end cap is shown in figure 4.

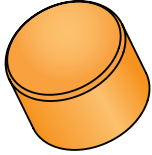

Figure 4: End caps.

Capillary Tubes and Sampling Ports

A capillary tube is a length of flexible tubing that is connected to the main sampling pipe with a sampling port at the end. The purpose of these tubes is to extend the placement of the area being sampled away from the main pipe network. This may be necessary to reach in to an enclosed space, such as a cabinet, or for aesthetic or security reasons. This allows the core pipe network to be hidden while only a small sampling port is located in the main space. Figure 5 shows the capillary tube extending down from the main sampling pipe with a sampling port at the end. PipelQ allows for capillary tubes and sampling ports to be added to the pipe network design and will calculate the appropriate air flow through the system.

The maximum length for capillary flexible tubing is 26 ft. (8 m). When multiple capillary tubes are used in a network, the length of each capillary tube should be approximately equal.

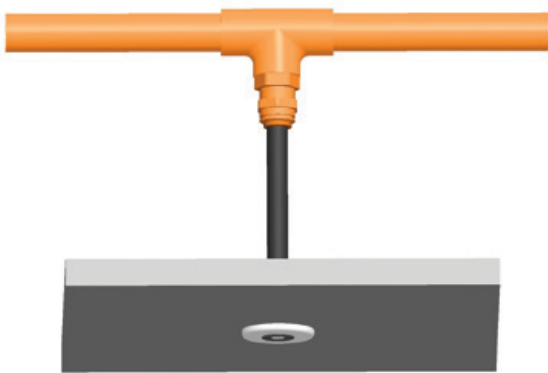

Figure 5: Capillary tubes and sampling ports.

Mounting Brackets

The pipe network is mounted to the ceiling, or other appropriate location, using mounting brackets. A large variety of brackets are available from a standard pipe supplier. Typical brackets include clips, saddle clamps, or tie wraps, as shown in Figure 6. The mounting choice will depend on the material being mounted to, environmental temperature, and local codes and regulations. Mounting brackets are usually centered 5 ft. (1.5 m) apart when using 3/4" schedule 40 pipe at 70°F (21°C). At 140°F this spacing reduces to 2.5 ft. between support brackets. Open style mounting clips should not be used in an inverted position with the open section facing downward, because the pipe could drop from the clip.

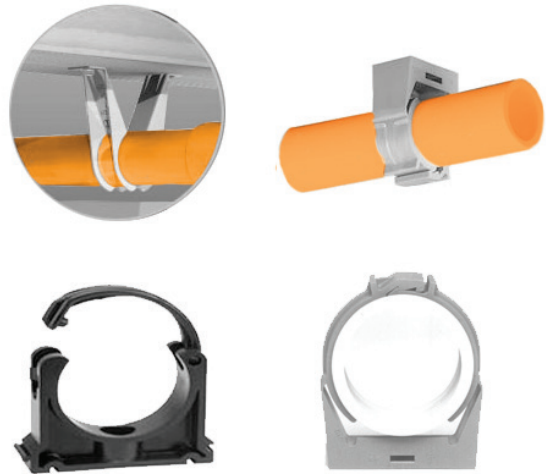

Figure 6: Mounting brackets.

Labels

Labels are available to identify the pipe network as a fire detection system, both at the sampling ports and along the pipe itself. NFPA 72® states that the pipe should be labeled:

1. At changes in direction or branches of piping
2. At each side of penetrations of walls, floors, or other barriers
3. At intervals on piping that provide visibility, but no greater than 20 ft. (6.1 m)

Pipe Network Installation

This section provides the basics to installing a pipe network. Keep in mind that each system will have different characteristics, and will have variations to accommodate. The most common issues are described in the following sections. To ensure a pipe network performs as expected, it must be designed in PipeIQ and installed as specified by the software.

Cutting Pipe

Proper tools must be used when cutting pipe. Pipe shears or a wheel type plastic tubing cutter can be used for plastic pipe. Always keep the cutting edge of the tools sharp. Ensure that cuts are made perpendicular to the pipe length, keeping the cuts square. Square cuts ensure maximum bonding area and help provide a good seal when joining the components.

Remove all loose material and any burrs from the end of the pipe after a cut. Debris and shavings from cuts must be removed in order to keep sampling ports free of obstruction.

Joining Components

The pipe network must be permanently connected once the system has been installed and tested. The method to accomplish a permanent connection depends upon the material of the pipe and fittings.

NOTE: The immediate connections between the inlet pipe and exhaust pipe and the FAAST detector SHOULD NOT be permanently connected.

When bonding components together, never apply solvent on the inside of a pipe or other component. Apply the solvent only to the outside of the pipe that is being inserted into a coupling or other component. If a solvent is applied to the inside of a pipe or other component, the solvent can build up. This build up can affect the air flow within the pipe network and may cause abnormal behavior within the pipe network.

Make sure that pipes are inserted completely and butted against the lip of the coupling or other component. If this is not done, turbulence can be created due to the gaps, which can cause problems with system pressures and air flow.

Frequently Asked Question – Is there a specific glue that must be used when assembling the network piping?

Yes, glue that is listed for the type of pipe used. When applying the glue be cautious not to leave excess residue inside the pipe. This can trap dust or dirt particles that can possibly affect the airflow of the detector over time.

Prior to drilling any sample ports, the pipe network should be checked for leaks. This can be done by pushing blank end caps onto pipe ends and/or covering sample ports with tape and applying low pressure air to the system to check for pressure decay.

Mounting the Pipe Network

The following recommendations should be taken into consideration when mounting the pipe network.

- Minimize flexing of the pipes by securing them at proper intervals with appropriate mounting brackets.

Maximum Support Spacing at Ambient Temperature

| Pipe Diameter | 60°F (16°C) | 100°F (38°C) | 140° F (60°C) |
|-----------------|-----------------|---------------|-----------------|
| 1/2 in. (15mm) | 4.5 ft. (1.3 m) | 4 ft. (1.2 m) | 2.5 ft. (0.7 m) |
| 3/4 in. (20 mm) | 5 ft. (1.5 m) | 4 ft. (1.2 m) | 2.5 ft. (0.7 m) |

Table 2: Maximum support spacing at ambient temperature.

- Typically, the pipe network should be mounted between 1 and 4 in. (25 – 100 mm), maximum of 12 in. (300 mm), below the ceiling, subject to local codes and regulations.
- Allow for expansion and contraction of the pipe network in areas of extreme temperature fluctuations, especially on long straight pipe runs.
- In areas of extreme temperature fluctuations, never place mounting brackets adjacent to couplings, unions or tees. This can lead to interference with expansion or contraction of the pipe network.
- To minimize the effect of pressure differentials that could affect the air flow of the system, the sampled air must be returned to the protected environment via exhaust tubing wherever possible.

Pipe Bends

Never bend pipes unless absolutely necessary. Use elbows, tees, or other fittings to change direction of the pipe.

If bending is necessary, determine how much bending the pipe can tolerate before beginning the process. Always use bending springs and pipe benders. Bending a pipe without heat will cause the PVC to shatter. Never heat the pipe or bend it around sharp objects. If a pipe creases or buckles while bending, replace it with a new section of pipe. Conform to all local codes and regulations for bending of pipes.

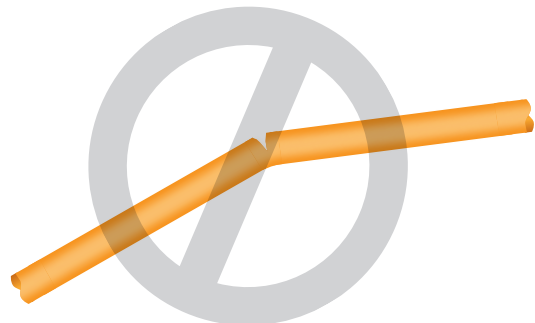

Figure 7: Pipe bends.

Drilling Sample Ports

Each port in a sampling pipe represents a smoke detection location. Port placement and size are determined using the PipelQ software. Sample ports should be measured, marked, and drilled before the network is installed. To prevent sampling ports from being blocked by dust and dirt, place ports on the bottom side of the sampling pipe, not the top side. This ensures that any falling debris does not clog the sampling ports. This port positioning should also be followed for voids in the ceiling or floor.

The following guidelines should be followed when drilling the sample ports in the pipe network.

- Ports must be drilled perpendicular (90 degrees) to the pipe. If the drill is not held perpendicular, the port is not round and not modeled properly in PipelQ.
- Tapering the ports reduces dust collection at the sample ports.
- Sampling ports must be drilled exactly at the positions marked on the pipe with the exact size as determined by the PipelQ software.
- Ports must not be drilled through both sides of the pipe.
- Ports should be drilled with a slow speed drill with a sharp drill bit. This minimizes dust and burrs entering the pipe network.

It is good practice to blow compressed air through the pipe after drilling to clear any debris before final connection to the FAAST detector. Alternately, a shop vacuum can be used to remove debris from the pipe network. Ensure that the pipe is disconnected from the FAAST detector when vacuuming pipe.

Installation Stages

Table 3 lists the standard installation stages for an aspiration pipe network.

| STEP | ACTION |
|------|--|
| 1 | Verify design documents are accurate and obtain the size and configuration of the pipes in the network. Note: If PipelQ was used to design the network, a bill of materials can be generated from the application. |
| 2 | Mark off the area where the system is to be installed and identify the location where the FAAST detector is to be mounted. |
| 3 | Select and mark the locations for the pipe clips in accordance with the design. |
| 4 | Install the FAAST detector in its permanent location. (See Installation and Maintenance Guide for details.) |
| 5 | Mount the pipe clips according to the previous markings. |
| 6 | Dry mount and assemble the pipe network according to the pipe network design documents. CAUTION: Do not permanently connect the pipes at this time. |
| 7 | Measure and mark the sampling ports on the pipe network. Make sure that the spacing of the sampling ports is in accordance with the network design. Based upon the application, ensure that the sampling ports are at the correct orientation to the air flow, as recommended in the section on network pipe design. |
| 8 | Modify the design documents to agree with the actual network, if the physical network is different from the original design, this new layout should be re-designed and confirmed in PipelQ prior to drilling sampling ports. |
| 9 | Verify the sampling port positions and orientations and drill the sampling ports. |
| 10 | Drill and install end caps on all appropriate pipe ends. |
| 11 | When testing is complete and the system performance is verified, permanently bond the pipe network together. CAUTION: Never bond the pipes to the detector. The detector inlet and outlet are tapered to accept the piping without any bonding and provide an air tight seal. |
| 12 | Label all portions of the system according to local codes and regulations. Pipe and Sampling Port labels are available – refer to the Accessories section. |
| 13 | If additional changes are made, ensure that design documents are updated accordingly. |

Table 3: Installation steps.

Application and Design

This section is intended to provide general design and application guidelines for designing pipe networks in conjunction with the FAAST system. It contains design considerations and recommendations on how the FAAST system may be installed in various applications.

Design

There are basic requirements that must be followed for a good site design. The more information that is obtained up front, the easier the process will be. The following list is good information to have when designing a pipe network.

- Understand local codes, standards, and regulations
- Gather all relevant information about the site, including the floor plan for the protected space. The floor plan must also include existing or proposed fixtures, fittings, air handlers, vents and other equipment that requires special consideration.
- Determine the uses of the protected area to establish any special requirements.
- Verify the protection level required for the area, i.e. Standard, Early Warning, or Very Early Warning Fire Detection.
- Use the PipeIQ software to design the pipe network for the FAAST detector.

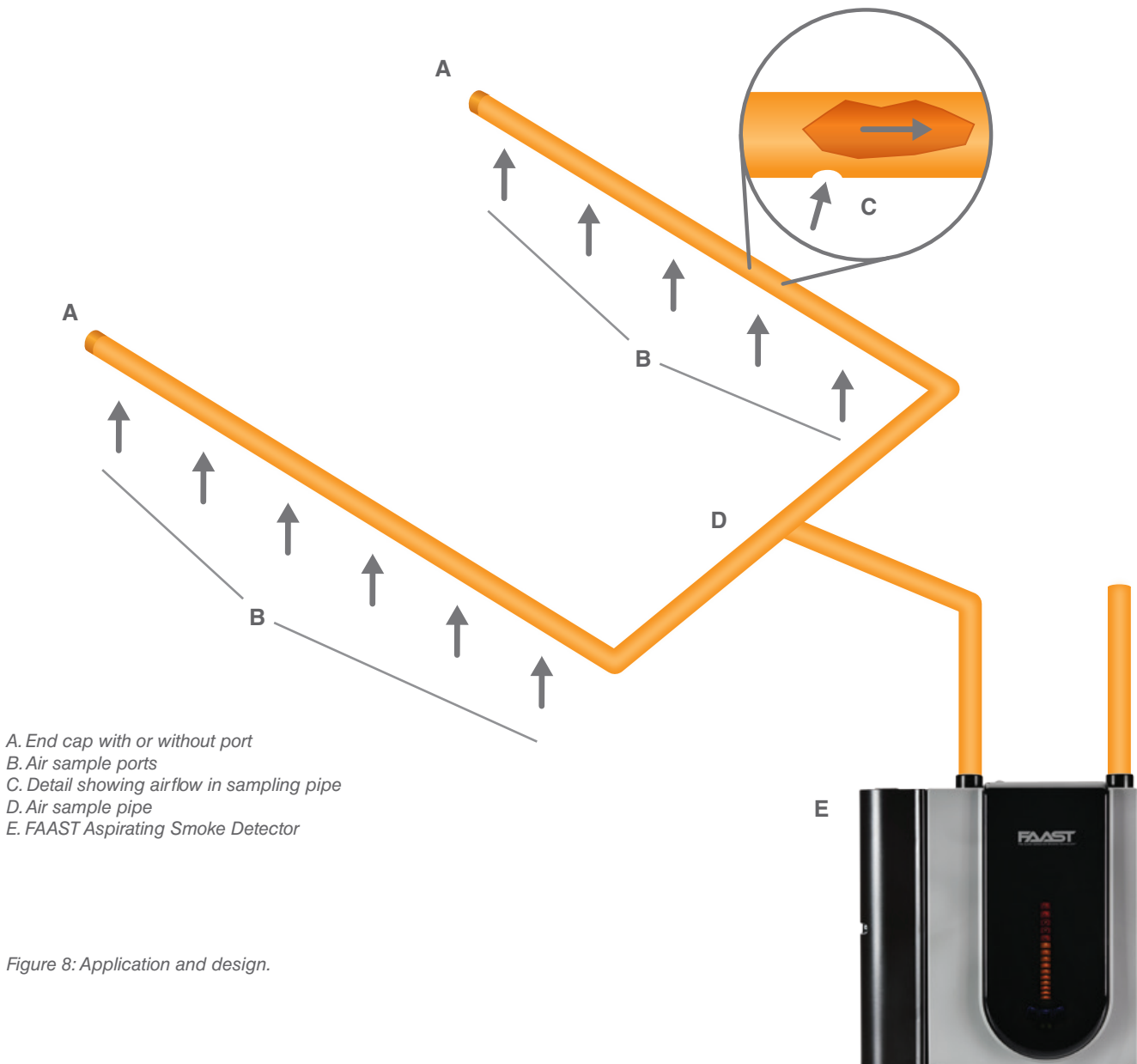

Figure 8: Application and design.

Regulatory Requirements

Local codes and regulations can determine the size and spacing between the sample ports in a network, making them a critical part to any pipe design. These requirements change depending on the type of environment being monitored. Local codes and standards take precedence over any parameters suggested by this document for FAAST systems.

Frequently Asked Question: How should the sample ports be spaced?

Sample port spacing varies worldwide based on regulatory standards. In the United States, sample ports shall be spaced as defined per the requirements of NFPA. Each application varies depending on the design. The requirements for sample port square footage coverage is based on the detection (Very Early Warning, Early Warning, or Standard) the design is attempting to meet.

Transport times and obscuration levels required at each sample port are as below:

Very Early Warning Fire Detection (VEWFD):

Sample port spacing: 200 sq. ft.
 Transport time: 60 seconds from further port (includes test port)
 Sample port sensitivity at pre-alarm: 0.2%obs/ft.
 Sample port sensitivity at alarm: 1.0%obs/ft.

Early Warning Fire Detection (EWFD):

Sample port spacing: 400 sq. ft.
 Transport time: 90 seconds from further port (includes test port)
 Sample port sensitivity at alarm: 1.5%obs/ft.

Standard Fire Detection (SFD):

Sample port spacing: 900 sq. ft.
 Transport time: 120 seconds from further port (includes test port)
 Sample port sensitivity at alarm: 3.2%

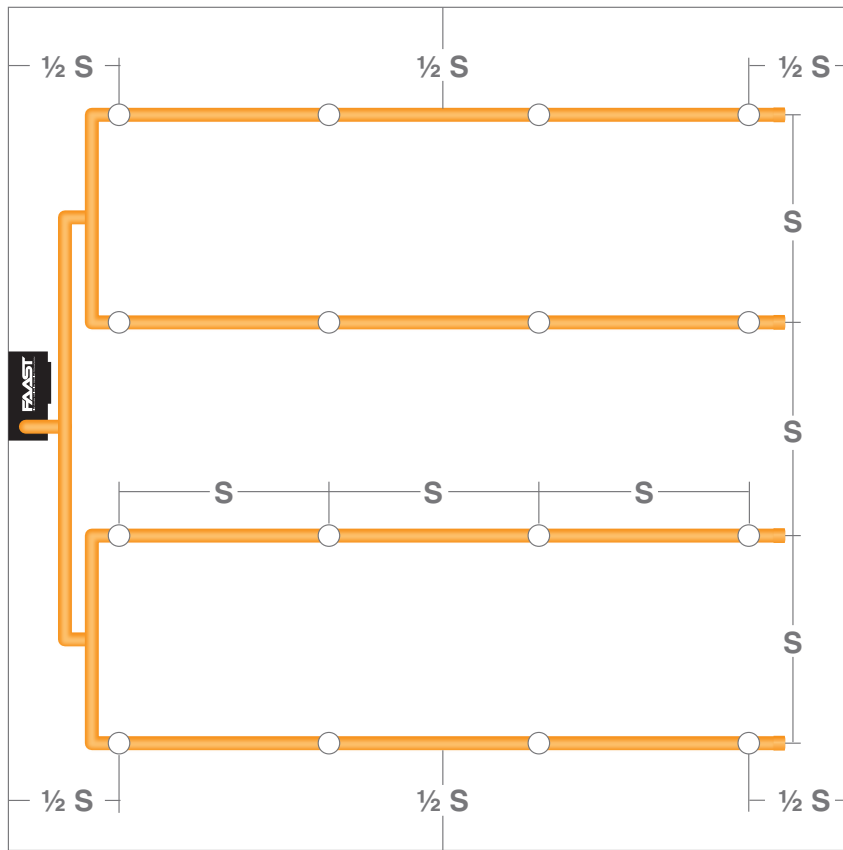

This figure indicates the sample port spacing for each classification requirement. The "S" indicates the maximum distance allowed per sample port while "1/2 S" indicates the maximum distance a sample port can be from a wall. Each design will vary based on the shape of the building but this template should be used as a starting point.

| Design Classifications | | | |
|------------------------|----------------------|-----------------------------------|-----------------------------------|
| Classification Type | Area Per Sample Port | Maximum Spacing Between Ports (S) | Maximum Spacing From Wall (1/2 S) |
| VEWFD | 200 sq. ft. | 14 ft. | 7 ft. |
| EWFD | 400 sq. ft. | 20 ft. | 10 ft. |
| SFD | 900 sq. ft. | 30 ft. | 15 ft. |

Figure 9: Regulatory requirements.

Site Layouts and Measurements

Planning of fire protection zones and relevant FAAST system locations are needed to begin the planning process. The plan should include measurements of the area to be protected and any areas designated for a different use. The plan should also show any obstacles to the flow of air in the space, i.e. partitions or other large objects. Areas requiring special protection should also be noted.

Locations of large machinery, equipment, cabinets or any other large items that may affect the pipe network design also need to be identified on the plan.

Site Details

When designing the FAAST system, there are a number of site details that need to be taken into account:

- Air flow and the location of air handling units, returns, exhaust systems, etc.
- Construction of areas being monitored – high ceilings, ceiling and floor voids, soffits
- Obstructions to pipe layout – beams, walls, furniture, etc.
- Placement of equipment requiring any special protection – electrical cabinets, etc.
- Monitoring requirements – on-site, remote
- Activities within the environment – public space, office space, clean room, warehouse, etc.
- Room temperature of the area being monitored and the area where the detector will be located.
- Pressure differentials of each area if monitoring multiple rooms with one detector.

Environmental Conditions

Identify any ambient conditions that exist within the protected area. Typically different areas have different conditions. This includes information such as temperature, humidity, and altitude. The more accurate the information about the protected areas, the better the FAAST system can be designed to meet those needs.

The environment, both internally and externally of the protected environment (especially if air is being pulled in for heating or cooling), may have an effect on the operation of the FAAST detector. Areas with high air movement can cause unwanted pressure differentials across the FAAST device if the device is not plumbed properly. High pollution levels may cause background levels of particulate matter in the protected area. The Acclimate feature of the FAAST system helps to compensate for this background level. This setting may be chosen during configuration of the FAAST device. If the environment is better defined by days of the week, the FAAST detector offers a day/night/weekend mode.

In locations that are normally subjected to difficult environmental conditions, such as loading docks or warehouse spaces, the FAAST detector is typically located within a controlled environment, while the pipe network is located in the harsh environment. In such applications the exhaust piping shall return to the area being monitored.

System Design

PipeIQ is designed to take the information gathered during this initial phase and assist in designing the pipe network. There are two design methods within the PipeIQ software. One offers a design wizard to create a simple layout based on the parameters provided. The other allows for customization throughout the process. Both methods provide the opportunity to go back and modify the system as needed to accommodate the environment being protected.

Sampling Methods

There are two general types of sampling methods: standard pipe network sampling and capillary tube sampling. From these sampling methods, several design configurations can be used to meet the needs of a particular site environment. Local codes and standards along with site requirements will help determine the best air sampling method.

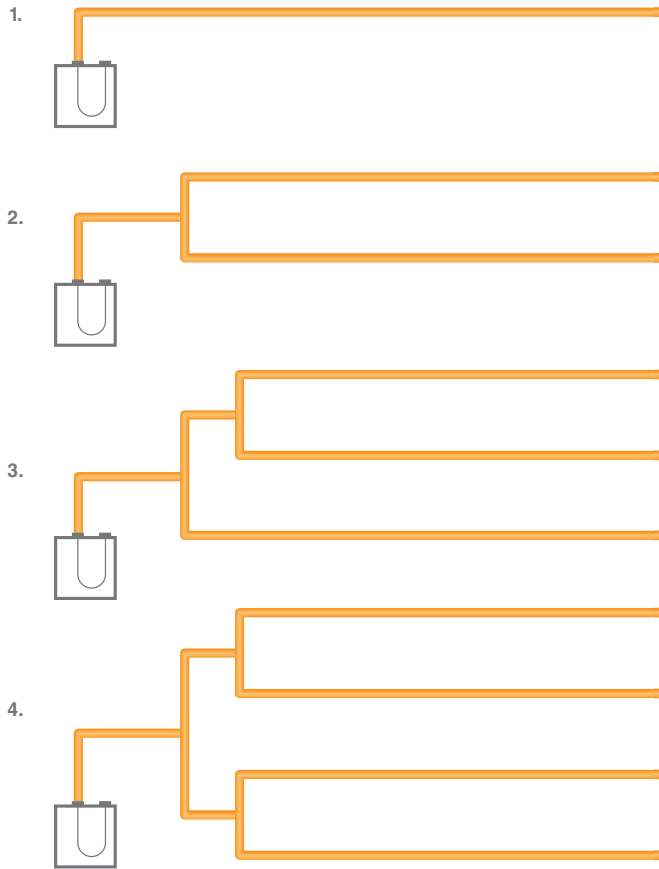

Figure 10: Sampling methods.

Standard Pipe Network Sampling

The following guidelines are used for any pipe network design. Also, some additional guidelines specific to different sampling methods may apply.

1. Local codes and standards always take precedence over any values specified in this document.
2. Recommended pipe network material is nominal 3/4" schedule 40 internal diameter (25 mm OD) CPVC, PVC, ABS or UPVC pipe.
3. Sharp bends decrease airflow and performance.
4. All pipe designs must have an end cap.
5. Multiple shorter pipes provide better performance than a single longer pipe.
6. Symmetrical (Balanced) designs in pipe length, port size, and port distribution are preferred to optimize FFAST system performance.

7. To prevent sampling ports from being blocked by dust and dirt, taper and place the ports on the bottom side of the sampling pipes, not on the top of the pipes. This ensures that any falling debris does not clog the sampling ports.
8. To minimize the effect of pressure differentials, the sampled air must be returned to the protected space wherever possible. This eliminates any pressure differentials that might reduce the air flow in the pipe network.

Capillary Tube Sampling

Capillary tube sampling is a method of locating sampling ports remote from the main sampling pipe. This is particularly useful where the main sampling pipe cannot be routed through the area requiring protection for either technical or aesthetic reasons. Capillary tubes are also used to sample equipment cabinets or enclosures within the protected area.

In the absence of other guidance, it is recommended that a minimum of two capillary sampling ports are sited in a room. PipeIQ will allow sampling ports and capillary tubes to be added as part of the design parameters. Local codes and standards differ on issues, such as the minimum distance that detection ports can be positioned from walls and ceilings. It is important that the specific local regulatory requirements are observed.

The following guidelines are recommended for capillary tube use.

1. Try to keep the length of capillaries the same.
2. Capillary tube length should not exceed 26 ft. (8 m)
3. When sampling equipment cabinets or other enclosures, the sampling port is typically placed at or close to the top of the interior of the enclosure.

Frequently Asked Question – Can I paint the capillary port?

It is not recommended to paint the capillary port, but in certain circumstances where aesthetics is a key feature, painting may be allowed pending the approval of the local authority having jurisdiction. If approved, the capillary port should be painted and dried before the port is drilled. A sample port identification label will be required to comply with NFPA.

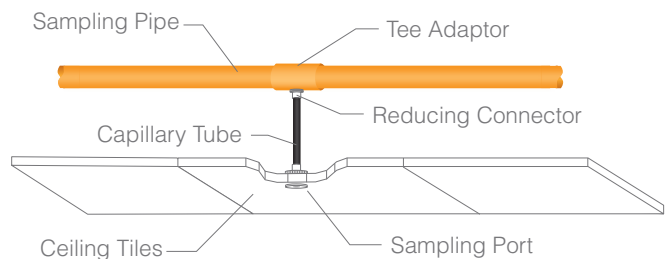

Figure 11: Capillary tube sampling.

Open Area Protection

Ceiling Sampling

In typical ceiling installations, the pipe network is suspended from 1" to 1 ft. (25 mm to 300 mm) below the ceiling level in the protected area unless otherwise specified by local codes and standards. This type of installation is the most common. It could be used in offices, warehouses, equipment rooms and a variety of other types of installations. PipeIQ can also help provide guidance for the design.

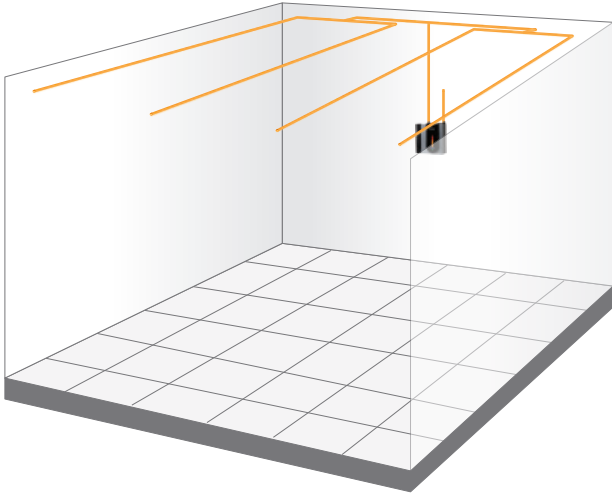

Figure 12: Ceiling sampling.

Frequently Asked Question – How do I design for a peak ceiling?

When designing peak ceiling applications, the spacing requirements of NFPA-72® apply. A sample port shall be provided within 36" from the center of the peak on both sides. The next sample port from the center shall comply within the design parameters of VEWFD, EWFD or SFD. If stratification could potentially occur, it is recommended to also provide sample ports along the wall.

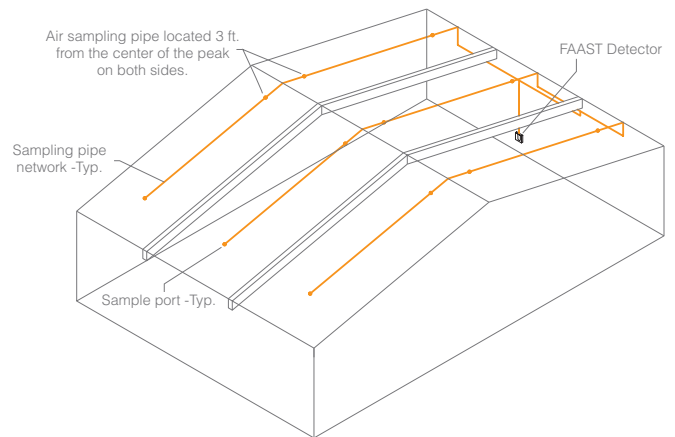
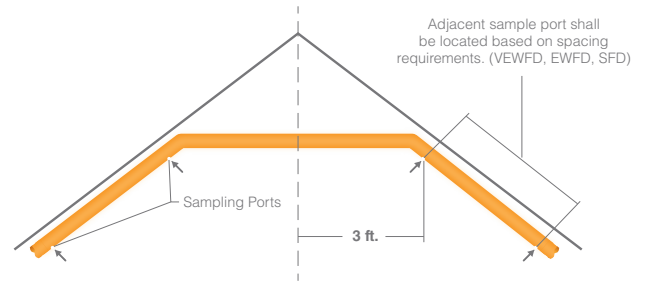

Figure 13: Peak ceiling sampling design.

Inter-Beam / Below-Beam Sampling

When large ceiling beams are used in construction, pockets of space are created between the beams. In normal circumstances, the pipe network is mounted on the bottom of the beams and does not sample the large space between the beams. If it is necessary to cover this space, a rigid pipe in the shape of an inverted “L” can be extended vertically from the pipe network up into the area between the beams so that the pipe reaches up towards the ceiling in these locations. The sampling port should be drilled just before the end cap on the horizontal portion of the pipe. The ends of these sampling pipes should be capped with an end cap, which may or may not have a sample port based on the pipe network design.

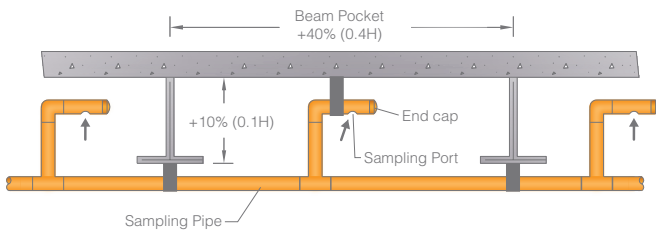

Figure 14: Inter-beam sampling.

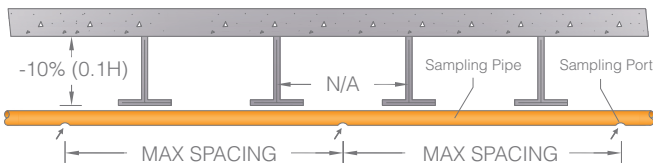

Figure 15: Below-beam sampling.

Frequently Asked Question – How do I know if the beam pocket has to be protected?

In exposed beam construction the sample port shall be spaced based on the requirements of NFPA 72®. If the beam depth is equal to or greater than 10% of the ceiling height and beam spacing is greater than or equal to 40% of the ceiling height, then detection shall be provided in each beam pocket per NFPA 72®. For beams with less than 10% of ceiling height, smooth ceiling spacing shall be permitted.

Under Floor Protection

Floor Void Sampling

The FAAST system is well suited to protect concealed voids, either in the ceiling or under the floor. Some locations use either ceiling and/or under floor voids as return air plenums (ducts). A pipe network must be designed to monitor the flow of return air through these areas. Some ceiling and floor voids are used for cable runs or for small equipment installation. Monitoring of these areas must be done using a pipe network designed for operation in these areas. When installing pipe in a floor void, keep in mind that the air sampling ports are still located at the bottom of the pipe. This means the pipe would be located towards the upper portion of the void.

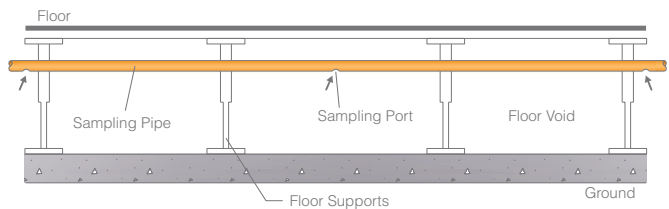

Figure 16: Floor void sampling.

Frequently Asked Question – Can I monitor the ceiling and under the floor with one detector?

FAAST can monitor two areas with one detector, however, it is not recommended practice due to pressure differentials. Areas with pressure difference of +/- 20% delta of one another can create air flow faults. Therefore it is recommended to provide each area with its own detector.

Floor Void Test Sample Port

It is recommended to install a test sample port when designing an under floor system. A test sample port will allow an easier commissioning process without disrupting the floor operation. It is recommended to locate the test port at the end of each branch pipe at a minimum of 18 in. above the raised floor. The port diameter should be determined and verified by using the PipeIQ Software.

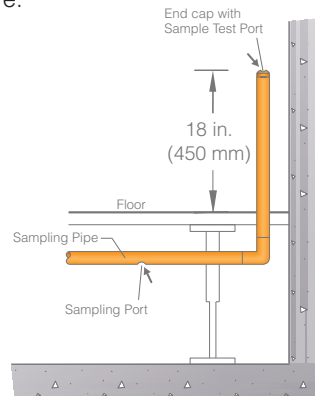

Figure 17: Floor void test sample port location.

Object Protection

Cabinet Sampling

Equipment cabinet sampling may be accomplished in two ways: pipe networks and sampling ports can be installed directly inside the equipment cabinet, or directly over the equipment cabinets being monitored if the cabinets have ventilation grills.

In-Cabinet Sampling

For in-cabinet sampling, capillary tubes can be used to enter the equipment cabinet. The capillary tube is connected to the pipe network via a tee connection with an adapter. The maximum length of these capillary tubes is 26 ft. (8 m). PipeIQ can help create an appropriate design.

An alternate to capillary tubes is a rigid drop tube. In this application, the pipe network is run over a row of cabinets and drop tubes are run down to each cabinet. This tube or pipe should be less than or equal to the network pipe diameter and is connected to the top of the cabinet and to the pipe network via a tee connection. The pipe could also come up from under a floor void in to a cabinet.

Cabinets with extractor fans may cause sampling problems when the sample port is on the top of the cabinet. The extractor fan creates a low pressure area within the cabinet that can stop air from being drawn into the detector system at the sampling port. This type of installation must be checked carefully for proper sampling operation. This can be accomplished using canned smoke at the sample port location.



Figure 18: In-cabinet sampling.

Above-Cabinet Sampling

In above-cabinet sampling, the pipe network should be installed directly over the cabinets that will be protected. Sampling ports are placed over the cabinet ventilation grills. Ports should be oriented so that they face into the air stream coming from the cabinet. If there is more than one exhaust from a cabinet, a sampling port should be installed over each opening.

NOTE: With either application, it is best to locate the sampling port in the path of the air flow near the top of the cabinet.

Top View of Cabinet



Figure 19: Above-cabinet sampling.

Large Area Protection

Large volume areas and areas with high ceilings require special design considerations for the pipe network design. Stratification occurs when smoke is heated by smoldering or burning materials and becomes less dense than the surrounding cooler air. The smoke rises until there is no longer a difference in temperature between the smoke and the surrounding air (see NFPA 72-2013 A.5.7.1.10). Stratification, therefore, may occur in areas where air temperature may be elevated at the ceiling level, especially where there is a lack of ventilation. When stratification is likely to occur, conventional pipe network sampling may not be effective.

One method to overcome smoke stratification is to create vertical sampling pipes in addition to the horizontal pipe network on the ceiling. The vertical sampling pipe should have sampling ports at various heights to sample within any stratification layers present in the area, as shown in figure 20.

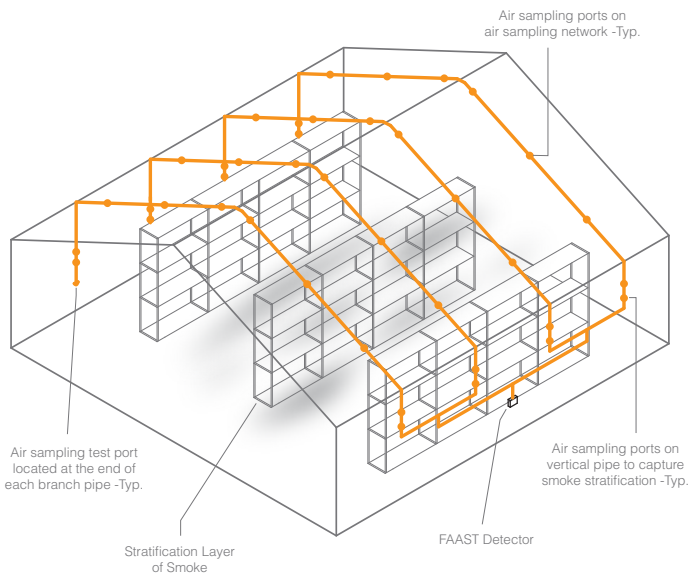

Figure 20: Large area protection.

Frequently Asked Question – Does FAAST eliminate stratification issues?

No, stratification occurs when smoke cools to a temperature equal to the surrounding air. To overcome the effects of stratification, provide sample ports on the pipe as it runs vertically up the wall. It is recommended to provide sample ports for stratification when the ceiling height exceeds 30 ft. or when ceiling elevations transition, creating a jet stream.

Cold Area Protection

The FAAST detector is approved for operating temperatures ranging from 32°F (0°C) to 100°F (38°C) and sampled air temperature from -4°F (-28°C) to 140°F (60°C). However, special considerations should be taken when operating at the extreme end of these ranges.

The temperature in a cold area is typically at or just above freezing. In designing a pipe system, the pipes should be kept out of the immediate airflow from a chiller unit, if used, as its air is often significantly colder than the room itself. Sample ports should also be located away from frequently used doors where possible.

Often, the temperature of the cold room is outside the operating temperature of FAAST and the device must be mounted outside of the room with the pipe network being run in to the protected space. Depending on the temperature of the air being removed from the room, heating elements may be required, and a condensation trap installed to catch any condensation or moisture that may enter the device.

For more information on deploying FAAST in cold storage applications, see the cold storage white paper at systemsensor.com/faast.

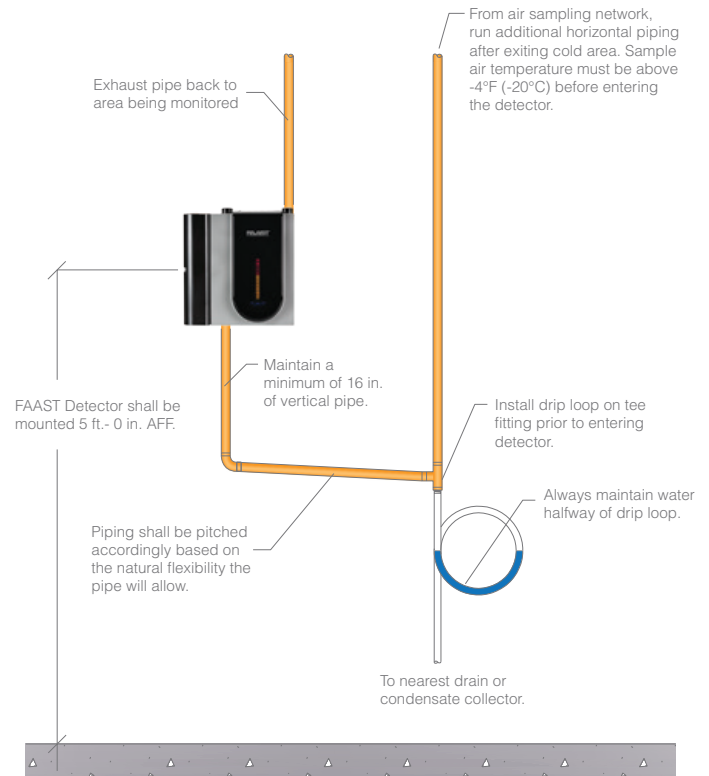

Figure 21: Cold area protection.

High Air Exchange Areas

Typically, high air exchange areas have some form of mechanical ventilation to maintain constant or cyclical air flow for heating, cooling or maintaining some other sort of special environment. Smoke tends to travel with the air flow, so positioning sampling pipes near the return of an air handling unit or heating/air conditioning unit ensures early detection of particulate in the area.

Normal sampling methods for high air exchange areas are a combination of return air and ceiling sampling. The return air sampling provides protection when the air flow is present. The ceiling network provides protection when the air flow is off. Local codes typically require smaller sample areas (closer spacing of sample ports) as the air flow rate increases.

Return Air Sampling

Return air sampling provides an effective means of Very Early Warning in a high air velocity environment. Placing the pipe network sampling ports directly in the air stream at a return air grill allows the system to monitor air that has circulated throughout the protected area.

The following guidelines should be reviewed and followed to ensure proper sampling by the detector system:

1. More than one sampling location may be required for large air grills. NFPA 76 recommendations specify that each sampling port can cover a maximum of 4 sq. ft. (0.4 m²)
2. Sampling ports should be aligned at an angle of 20 to 45 degrees to the direction of the maximum air flow.
3. Sampling pipes should be placed in the path of the greatest air flow.
4. The number of bends in the pipe network should be kept to a minimum.
5. Pipe ends should be capped with an end cap. Depending on the pipe design and PipelQ recommendations, the end caps may or may not have a sampling port.
6. Socket unions should be used in locations where the pipe network requires the removal of the pipes on a regular basis for maintenance purposes.
7. Use of standoff fittings to keep the pipe network at least 2" to 8" (50 mm to 200 mm) in front of the grill for high velocity air flow locations. Installing the network any closer to the input grill locates the sample port in an area of negative air pressure.
8. Always keep in mind that the monitored environment should still ensure coverage even if the manufactured air flow gets disrupted.

Generally the FAAST detector should not monitor more than two air handling units. When monitoring multiple units with one device, the AHUs should have similar flow at all times. The number of air handlers monitored is limited by the maximum length of the pipe network. However, the degree of particle dilution and air movement that occurs with multiple air handlers can adversely affect system response times. Final system testing should be done to confirm actual response times.

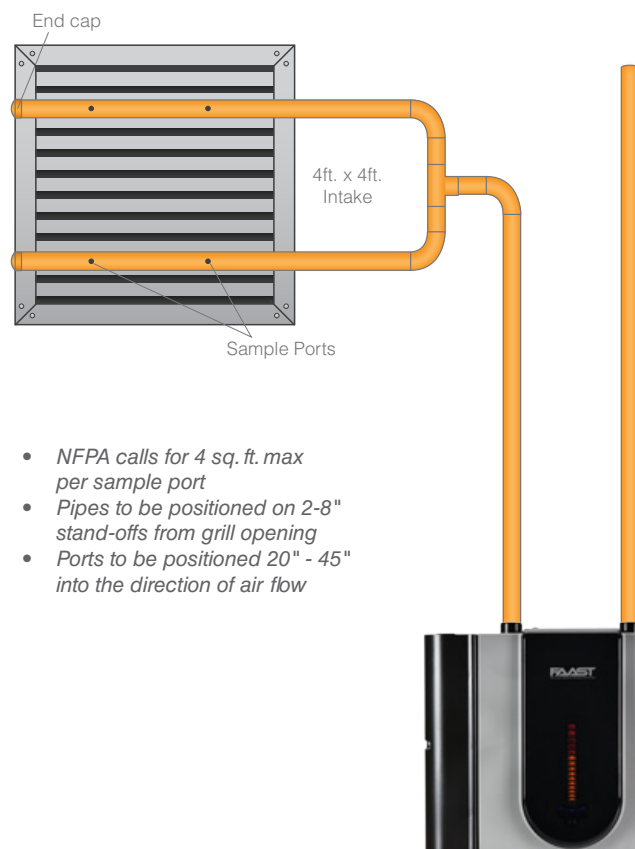

Figure 22: Return air sampling.

In-Duct Sampling

The FAAST detector is approved for in duct applications. National and local safety standards and codes recognize the ability of air duct systems to transfer smoke, toxic gases, and flame from area to area. Sometimes smoke can be of such quantity as to be a serious hazard to life safety unless blowers are shut down and dampers are actuated. The primary purpose of duct smoke detection is to prevent injury, panic, and property damage by reducing the spread (recirculation) of smoke. Duct smoke detection also can serve to protect the air conditioning system from fire and smoke damage, and can be used to assist in equipment protection applications, for example, in the ventilation/exhaust duct work of mainframe computers and tape drives. For additional information relating to duct applications, refer to the duct application white paper at systemsensor.com/faast.

Design Considerations for In-Duct Sampling

The following guidelines are necessary to obtain the best installation results.

1. Pipes should always be supported at both duct walls – rubber grommets can be used. Silicon sealer must also be used to ensure an airtight seal in the duct walls.
2. Inlet pipes must be inserted between six and ten duct widths or diameters (for round ducts) from any disturbances to the flow generated by sharp bends, plenums, nozzles, branch connections, etc...
3. Sampling ports should be located no closer than 2" to the duct wall.
4. Ports on the inlet pipe should face 20-45 degrees into the air flow with the ports concentrated at the center of the duct as shown in figure 22.
5. The exhaust pipe must have 4, 3/8" (9.5 mm) ports. Ports should be concentrated in the middle of the duct's width and spaced evenly. Ports on the exhaust pipe should be oriented such that they face away from the air flow.

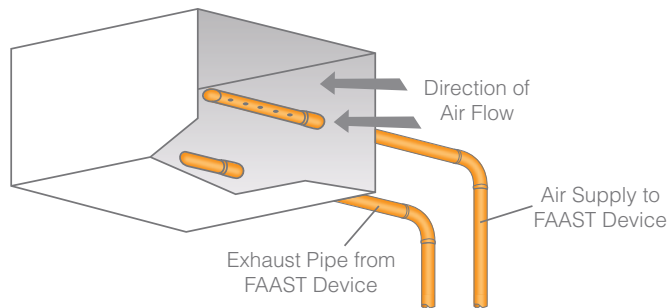

Figure 23: Design considerations for in-duct sampling.

Small Duct Sampling

For ducts with a width less than 3 ft. (1 m), the inlet pipe should be installed at the midpoint of the duct height or diameter. Exhaust pipes should be inserted at 18" (0.5 m) downstream from the input pipe. The exhaust pipe should be at one quarter of the duct height or diameter, as shown in figure 23. To avoid dilution, sampling pipes should be located before fresh air intakes and before the exhaust air output.

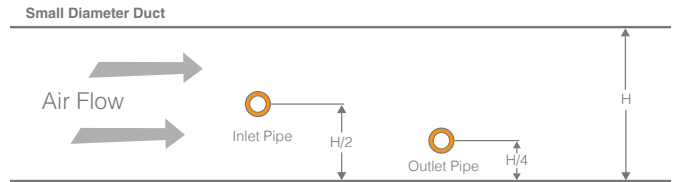

Figure 24: Small duct sampling.

| Duct Width | Number of Ports | Port Size | Nominal Pipe Flow Rate (CFM) |
|--------------------|-----------------|-----------------------|------------------------------|
| 12 in. (300 mm) | 2 | 1/4 in. (6.5 mm) | 1.84 cfm (52.0 L/min) |
| 20 in. (500 mm) | 3 | 1/4 in. (6.5 mm) | 1.83 cfm (51.9 L/min) |
| 28 in. (700 mm) | 4 | 11/64 in. (4.5 mm) | 1.70 cfm (48.1 L/min) |
| 36 in. (900 mm) | 5 | 5/32 in. (4 mm) | 1.81 cfm (51.2 L/min) |

Table 4: Port sizes for small ducts.

Large Duct Sampling

For ducts with a width of 3 ft. to 7 ft. (1 m to 2 m), two branch pipes are recommended for the inlets. Inlet pipes should enter a quarter of the way from the top and bottom of the duct, as shown in figure 24.

The exhaust pipe should be inserted approximately 18" (0.5 m) from the inlet pipes and half way up the height of the duct.

To avoid dilution, sampling pipes should be located before fresh air intakes and before exhaust air output.

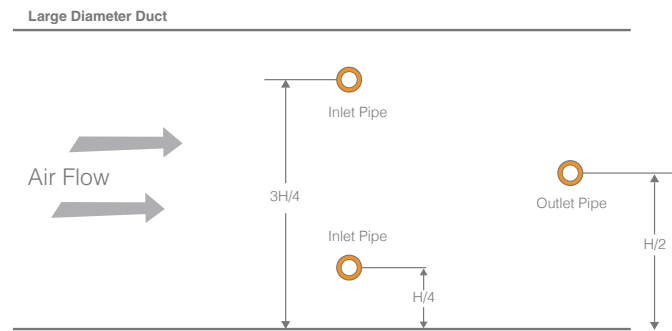

Figure 25: Large duct sampling.

| Duct Width | Number of Ports | Port Size | Nominal Pipe Flow Rate (CFM) |
|----------------------|-----------------|----------------------|------------------------------|
| 3 ft. 4 in. (1 m) | 6 | 9/64 in. (3.5 mm) | 1.77 cfm (50.2 L/min) |
| 5 ft. (1.5 m) | 8 | 1/8 in. (3 mm) | 1.80 cfm (50.9 L/min) |
| 6 ft. 6 in. (2 m) | 10 | 1/8 in. (3 mm) | 2.10 cfm (59.6 L/min) |

Table 5: Port sizes for large ducts.

The information in table 4, on page 17, and table 5, above, applies to a 15 ft. (4.6 m) inlet pipe and a 10 ft. (3 m) exhaust pipe. Always check local codes and standards for port size and spacing.

Port Orientation

Sampling response time can also be improved by avoiding high and low velocity air flows. Ports on the inlet pipes should be facing 20-45 degrees from the airflow. The angle of the ports can be adjusted for complete flow independence from the AHU by following some simple steps outlined in the Duct Application white paper on the FAAST website. Ports on the exhaust pipe should be facing away from the airflow.

For additional information relating to duct applications, refer to the duct application white paper at systemsensor.com/faast.

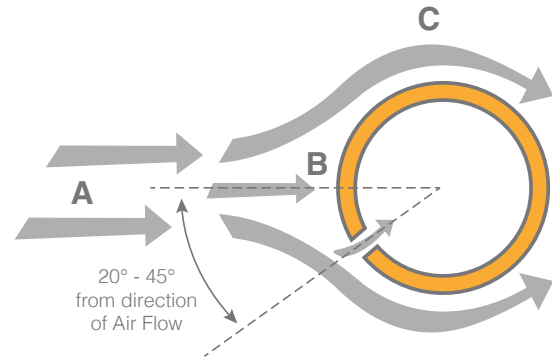

- A. Airflow Streamlines
- B. Low velocity (high static pressure) area
- C. High velocity (low static pressure) area

Figure 26: Port orientation.

Monitoring Voids

In these high air exchange environments, detection systems should be installed in any void, unless the void is completely empty and presents no fire risk. If the void contains cabling and/or equipment that can initiate or contribute to a fire, monitoring for combustion is highly recommended. The sampling port spacing for these areas is the same as the requirement for the rest of the area, in accordance with the relevant local codes and standards.

When sampling pipes are installed in shallow voids having poor ventilation, special care should be taken to position the piping as close to the top of the void as possible. This gives the best early warning due to the likelihood of the initial smoke layer taking up only the top 10% of the void height.

Basic Pipe Network Cleaning and Maintenance Procedure

Periodic maintenance of the FFAST Fire Alarm Aspiration Sensing Technology pipe network is recommended in environments with high amounts of airborne particulate, or cold environments where condensation may freeze on the sampling port and affect pipe network performance. Annual maintenance of the pipe network is recommended for all installations.

Low flow faults on devices which have been installed and operating normally for a period of time may signal the need for pipe network cleaning.

Pipe Network Maintenance

During installation of the pipe network, it is recommended that a valved tee fitting be installed 6 inches to 1 foot from the pipe inlet so that the pipe entering the detector is not subject to any flow of air during the pipe network maintenance. Forcing air in to, or out of, the FFAST unit by any means other than the inherent fan may cause damage to the device and nullify the device warranty.

Prior to beginning pipe network maintenance:

- Place the device in isolate or disable mode, or power down.
- Remove the pipe network from the device, or switch the valve on a valved tee fitting to ensure that no air can be force in to or out of the device

To perform pipe network maintenance:

- Affix a vacuum cleaner, or air compressor, to the end of the pipe network or the entry in to the valved tee fitting.
- While the vacuum is running, use a dry brush or pipe cleaner to swab out each sampling port in the pipe network. Leave vacuum running for 2 min following last port cleaning.

Post pipe network maintenance:

- Reconnect pipe network to the FFAST device or switch the valved tee tap
- Remove the device from isolate or disable mode, or reapply power to the FFAST
- Observe the air flow pendulum on the user interface. The two green indicators should be near center underneath the device's power indicator. If a low condition existed before maintenance, this condition should be clear after maintenance (NOTE: if the device is set to latch in fault, the device will need to be reset to clear the fault)

- If the low flow condition persists, perform another manual check of the pipe network against the pipe layout report generated by PipelQ. Also, if the exhaust pipe is not situated in the protected space the low/high flow condition could be the result of differences in room pressures that have changed do to open doors, windows or upgrades to ventilation units.

Filter Maintenance

Filter maintenance is required only when a 'Filter' fault is indicated by the FFAST unit. Perform the following procedure to replace the filter assembly:

1. Remove power from the system.
2. Open the door on the right side of the device that covers the LED system indicators.
3. Remove the plastic name card over the LEDs.
4. Remove the two screws holding the filter assembly into the device.
5. Remove the filter assembly and replace it with a new assembly.
6. Torque the two Phillips-head screws to 6in-lb (0.7 N-M) or ¼ turn past "lightly snug". DO NOT OVERTIGHTEN.
7. Replace the plastic name card over the LEDs.
8. Close the door and restore power to the system.

Technical Support

System Sensor strives to provide our customers with outstanding support for the FAAST Fire Alarm Aspiration Sensing Technology and all of our products. For more information, contact us using one of the methods below:

| Web: | E-mail: | Phone: |
|--|--|---|
| systemsensor.com/faast | systemsensor.com/contact | 800.736.7672 (press 2) Mon-Fri, 7:30 a.m. – 5:00 p.m. CST |